

JVC



9-INCH WIDE COLOR MONITOR

KV-MR9000

ENGLISH

**MONITOR COLOR DE PANTALLA ANCHA
DE 9-PULGADAS**

KV-MR9000

ESPAÑOL

**MONITEUR COULEUR À ÉCRAN LARGE
DE 9 POUCES**

KV-MR9000

FRANÇAIS

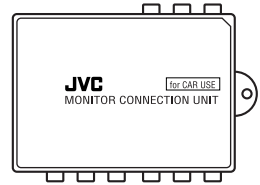
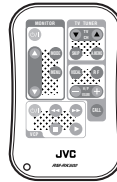
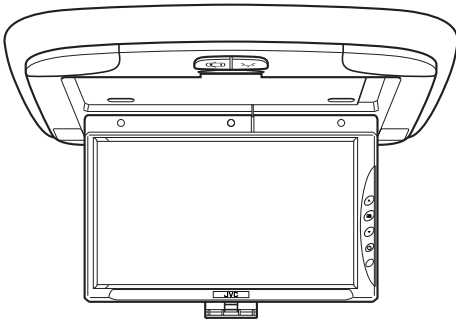

For installation and connections, refer to the separate manual.

Para la instalación y las conexiones, refiérase al manual separado.

Pour l'installation et les raccordements, référez-vous au manuel séparé.

* This system cannot receive television broadcasts and is primarily designed for use with a VCR or a DVD player. Use the separately sold mobile TV tuner unit KV-C10 for optional television broadcast reception.

* Este sistema no puede recibir emisiones de televisión y ha sido diseñado para utilizarse esencialmente con un VCR o un reproductor DVD. Utilice la unidad de sintonizador de TV móvil KV-C10 vendido por separado para una recepción opcional de emisiones de televisión.

* Ce système ne peut pas recevoir les émissions de télévision et il est essentiellement conçu pour l'utilisation avec un magnétoscope ou un lecteur de DVD. Utilisez le module de tuner de télévision mobile KV-C10 vendu séparément afin de pouvoir recevoir les émissions de télévision.

INSTRUCTIONS

MANUAL DE INSTRUCCIONES
MANUEL D'INSTRUCTIONS

For customer Use:

Enter below the Model No. and Serial No. which are located on the top or bottom of the cabinet. Retain this information for future reference.

Model No. _____

Serial No. _____

LVT0986-001A

[J]

	CAUTION RISK OF ELECTRIC SHOCK DO NOT OPEN	
CAUTION: TO REDUCE THE RISK OF ELECTRIC SHOCK, DO NOT REMOVE COVER (OR BACK). NO USER-SERVICEABLE PARTS INSIDE. REFER SERVICING TO QUALIFIED SERVICE PERSONNEL.		



The lightning flash with arrowhead symbol, within an equilateral triangle, is intended to alert the user to the presence of uninsulated "dangerous voltage" within the product's enclosure that may be of sufficient magnitude to constitute a risk of electric shock to persons.



The exclamation point within an equilateral triangle is intended to alert the user to the presence of important operating and maintenance (servicing) instructions in the literature accompanying the appliance.

WARNING:
TO PREVENT FIRE OR SHOCK HAZARD, DO NOT EXPOSE THIS UNIT TO RAIN OR MOISTURE.

CAUTION:
This monitor system should be used with DC 12V only. To prevent electric shocks and fire hazards, DO NOT use any other power source.

CAUTION:
This product has a fluorescent lamp that contains a small amount of mercury. It also contains lead in some components. Disposal of these materials may be regulated in your community due to environmental considerations. For disposal or recycling information please contact your local authorities, or the Electronics Industries Alliance: <http://www.eiae.org/>

Installation requires some special knowledge. Do not install the monitor system yourself. Consult a dealer having special knowledge of this kind for safe and reliable installation.

WARNINGS

- DO NOT INSTALL THE MONITOR IN A LOCATION WHICH OBSTRUCTS DRIVING, VISIBILITY OR WHICH IS PROHIBITED BY APPLICABLE LAWS AND REGULATIONS.
- THERE MAY BE LEGAL REGULATIONS DEFINING THE PERMISSIBLE INSTALLATION LOCATIONS FOR THE DISPLAY UNIT WHICH DIFFER BY COUNTRY OR BY STATE. BE SURE TO INSTALL THE DISPLAY UNIT IN A CORRECT LOCATION ACCORDING TO SUCH LAWS.
- DO NOT INSTALL THE MONITOR IN A LOCATION WHICH OBSTRUCTS THE OPERATION OF AN AIR BAG.
- THE DRIVER MUST NOT OPERATE THE MONITOR SYSTEM WHILE DRIVING. OPERATING THE MONITOR WHILE DRIVING MAY LEAD TO CARELESSNESS AND CAUSE AN ACCIDENT.
 - * STOP YOUR VEHICLE IN A SAFE LOCATION WHEN OPERATING THE MONITOR.
- THE DRIVER MUST NOT WATCH THE TELEVISION OR VIDEOS WHILE DRIVING. IF THE DRIVER WATCHES THE TELEVISION OR A VIDEO WHILE DRIVING, IT MAY LEAD TO CARELESSNESS AND CAUSE AN ACCIDENT.
- WHEN LIGHTNING OCCURS, DO NOT TOUCH THE ANTENNA WIRE OR THE TELEVISION. TOUCHING THE ANTENNA WIRE OR THE TELEVISION UNDER SUCH CONDITIONS MAY CAUSE ELECTROCUTION.
- KEEP THE MONITOR AT AN APPROPRIATE SOUND LEVEL WHILE DRIVING. DRIVING WITH THE SOUND AT A LEVEL THAT PREVENTS YOU FROM HEARING SOUNDS OUTSIDE OF AND AROUND THE VEHICLE MAY CAUSE AN ACCIDENT.
- ASK A TRAINED TECHNICIAN TO INSTALL THE MONITOR SYSTEM. INSTALLATION AND WIRING REQUIRE TRAINING AND EXPERIENCE.
 - * TO BE SAFE, ASK THE SALES OUTLET WHERE YOU PURCHASED THE MONITOR SYSTEM TO PERFORM THE INSTALLATION.
- BE SURE NOT TO LET THE MONITOR FALL OR BE STRONGLY IMPACTED SINCE THIS MAY CAUSE A MALFUNCTION OR FIRE.
- DO NOT USE THE MONITOR WITH THE ENGINE OFF. WATCHING THE MONITOR WITH THE ENGINE OFF WILL CONSUME BATTERY POWER AND MAY PREVENT THE ENGINE FROM STARTING.
- DO NOT USE ANY CEILING LIGHT BULBS OTHER THAN SPECIFIED FOR THIS UNIT (12 V, 3 W). FAILING TO DO SO MAY POSSIBLY CAUSE FIRE.
- WHEN NOT IN USE, CLOSE THE LIQUID CRYSTAL PANEL AND STORE IT INTO THE COMPARTMENT.

Thank you for purchasing a JVC product. Please read all instructions carefully before operation, to ensure your complete understanding and to obtain the best possible performance from the unit.

CONTENTS

PRECAUTIONS	4
CONTROLS AND FEATURES	5
Wide color monitor	5
Remote controller	6
Replacing the battery	7
BASIC OPERATIONS	8
Other basic operations	10
Activating the door sensor	10
Turning on or off the ceiling lights	10
Selecting the RF signals to the receiver	10
Using optional cordless headphones	10
ADJUSTMENTS	11
Using the Menu	11
Basic procedure	11
Adjustable items on the menu	12
MAINTENANCE	14
TROUBLESHOOTING	14
SPECIFICATIONS	15



INFORMATION (For U.S.A. only)

This equipment has been tested and found to comply with the limits for a Class B digital device, pursuant to Part 15 of the FCC Rules. These limits are designed to provide reasonable protection against harmful interference in a residential installation. This equipment generates, uses, and can radiate radio frequency energy and, if not installed and used in accordance with the instructions, may cause harmful interference to radio communications. However, there is no guarantee that interference will not occur in a particular installation. If this equipment does cause harmful interference to radio or television reception, which can be determined by turning the equipment off and on, the user is encouraged to try to correct the interference by one or more of the following measures:

- Reorient or relocate the receiving antenna.
- Increase the separation between the equipment and receiver.
- Connect the equipment into an outlet on a circuit different from that to which the receiver is connected.
- Consult the dealer or an experienced radio/TV technician for help.

BEFORE USE

* For safety....

- Do not raise the volume level too much, as this will block outside sounds, making driving dangerous.
- Stop the car before performing any complicated operations.

* Temperature inside the car....

If you have parked the car for a long time in hot or cold weather, wait until the temperature in the car becomes normal before operating the unit.



PRECAUTIONS

ENGLISH

Cautions for handling the liquid crystal panel

Do not expose the liquid crystal display to direct sunlight.

- Storage temperature range: $-20\text{ }^{\circ}\text{C}$ to $+80\text{ }^{\circ}\text{C}$ ($-4\text{ }^{\circ}\text{F}$ to $176\text{ }^{\circ}\text{F}$)

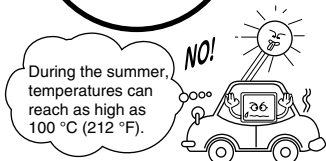
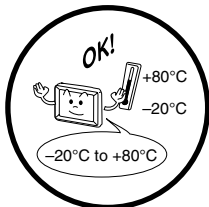

When the liquid crystal panel reaches high temperatures or low temperatures, chemical changes occur within the liquid crystal panel which may cause it to malfunction.

The red spots, blue spots and green spots on the panel surface are a normal characteristic of liquid crystal panels, and not a problem.

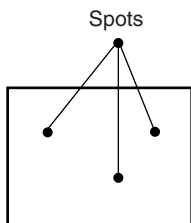

The liquid crystal panel is built with very high precision technology and has at least 99.99% effective image pixels. Be aware that on 0.01% of the panel there may be missing or constantly lit pixels.

Do not drop the liquid crystal display or strike it sharply.

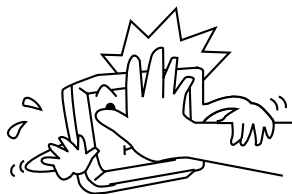

When the temperature is very cold or very hot, the image may not appear clearly or may move slowly.

The image may not be synchronized with the sound or the image quality may decline in such environments. Note that this is not a malfunction or problem.

- Usage temperature range: $0\text{ }^{\circ}\text{C}$ to $+40\text{ }^{\circ}\text{C}$ ($32\text{ }^{\circ}\text{F}$ to $104\text{ }^{\circ}\text{F}$)



$0\text{ }^{\circ}\text{C}$ ($32\text{ }^{\circ}\text{F}$) or colder

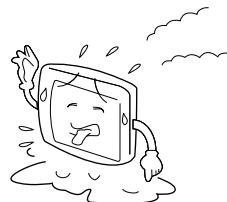

$40\text{ }^{\circ}\text{C}$ ($104\text{ }^{\circ}\text{F}$) or hotter



Wide color monitor

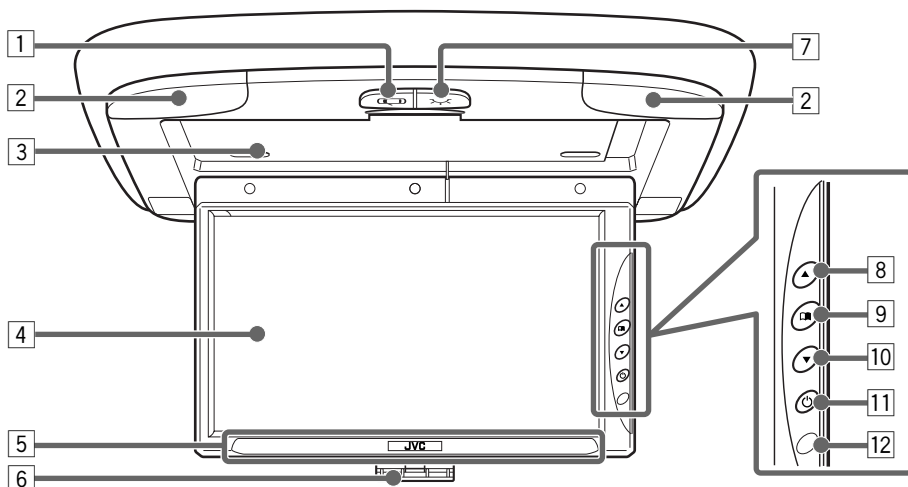





- 1 Door Sensor button ()**
 Activates or deactivates the door sensor which turns on the ceiling light when a door is open.

 - When the door sensor is turned on, this button glows red.
- 2 Ceiling lights**
- 3 Screen compartment**
 While not in use, close the screen and store it in this compartment.
- 4 Screen (Liquid crystal panel)**

 - When you open the screen, the monitor automatically turns on.
 - When you close it, the monitor automatically turns off.
- 5 IR transmitter**

 - See “Specifications” for cordless headphones.
 - It is recommended to use JVC’s cordless headphones KS-HP1K.
- 6 Screen hook**

 - Release from the screen compartment to use the monitor.
 - After using the monitor, close the screen, and hook to the screen compartment.
- 7 Ceiling Light button ()**
 Turns on or off the ceiling lights.
- 8 Up button ()**
 Increase the adjustment level of (or select an appropriate setting for) the item selected by the Menu button.
- 9 Menu button ()**
 Select an adjustment item.
- 10 Down button ()**
 Decrease the adjustment level of (or select an appropriate setting for) the item selected by the Menu button.
- 11 Power button ()**

 - Press to turn on the power.
 Each time you press the button, the input mode changes when the power is on.
 - Press and hold to turn off the power.
- 12 Remote sensor**
 Aim at this area when operating the monitor from the remote controller.

Note:

When you watch the screen at an angle, the picture might not be clear. This is not a malfunction. The finest picture can be seen when you watch the screen straight-on.

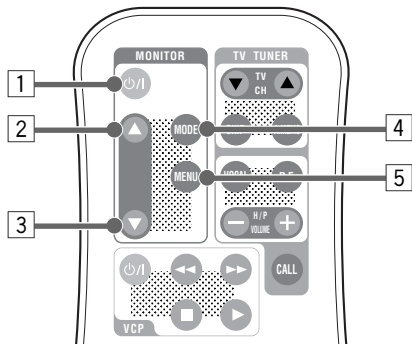
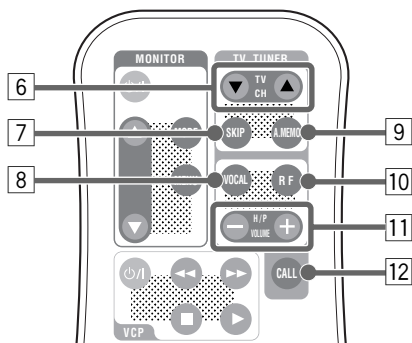
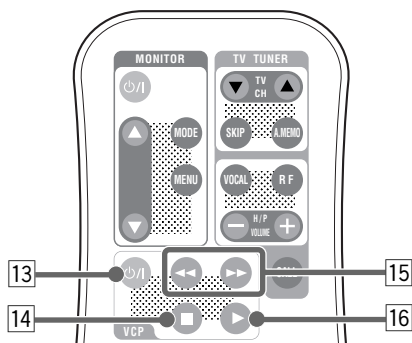
**Remote controller RM-RK500****Monitor section****TV tuner section****Video cassette player section****Monitor section**

- 1 **Power On/Standby button (⏻/⏻)**
Turn on or off the monitor system.
- 2 **Up button (▲)**
Increase the adjustment level of (or select an appropriate setting for) the item selected by the MENU button.
- 3 **Down button (▼)**
Decrease the adjustment level of (or select an appropriate setting for) the item selected by the MENU button.
- 4 **MODE button**
Each time you press the button, the input mode changes.
- 5 **MENU button**
Call up or erase the Menu screen.

TV tuner section

The following buttons can be used for operating JVC's KV-C10.

• For specific operations, refer to the instructions for the KV-C10.

- 6 **TV CH buttons (▲/▼)**
- 7 **SKIP button**
- 8 **VOCAL button**
- 9 **A.MEMO (auto memory) button**
- 10 **RF (radio frequency) button**
- 11 **H/P (headphones) VOLUME buttons (+/-)**
- 12 **CALL button**

Video cassette player (VCP) section

The following buttons can be used for operating JVC's KV-V8 or KZ-V10.

• For specific operations, refer to the instructions for the KV-V8 or KZ-V10

- 13 **Power On/Standby button (⏻/⏻)**
- 14 **■ (Stop) button**
- 15 **◀◀ (Rewind)/▶▶ (Fast-forward) buttons**
- 16 **▶ (Play) button**



Before using the remote controller:

When you use the remote controller for the first time, **pull out the insulation sheet** as illustrated to the right.

- Aim the remote controller directly at the remote sensor on the color monitor. Make sure there is no obstacle in between.
- Do not expose the remote sensor to strong light (direct sunlight or artificial lighting).

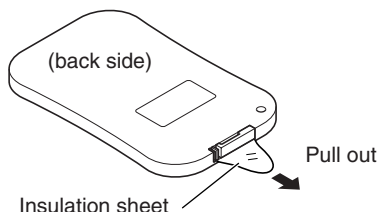

(The battery has been installed when shipped from the factory.)

Replacing the battery

When the controllable range or effectiveness of the remote controller decreases, replace the battery.

1. Remove the battery holder.

While pushing in the lock using a ball-point pen or a similar tool (①), pull out the battery holder in the direction indicated by the arrow (②).

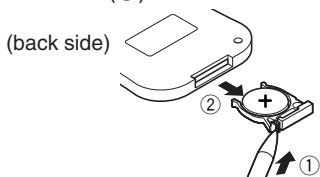

2. Replace the battery.

Slide a new battery into the holder with the + side facing upwards so that the battery is fixed in the holder.



3. Return the battery holder.

Insert the battery holder again pushing it until you hear a clicking sound.

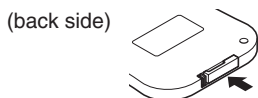

WARNING:

- Store the battery in a place which children cannot reach.
If a child accidentally swallows the battery, immediately consult a doctor.
- Do not recharge, short, disassemble or heat the battery or dispose of in a fire.
Doing any of these things may cause the battery to give off heat, crack or start a fire.
- Do not leave the battery with other metallic materials.
Doing this may cause the battery to give off heat, crack or start a fire.
- When throwing away or saving the battery, wrap in tape and insulate; otherwise, it may cause the battery to give off heat, crack or start a fire.
- Do not poke the battery with tweezers or similar tools.
Doing this may cause the battery to give off heat, crack or start a fire.

CAUTION:

DO not leave the remote controller in a place (such as dashboard) exposed to direct sunlight for a long time. Otherwise, it may be damaged.



BASIC OPERATIONS

ENGLISH

Preparation

Before operating the monitor system, make sure that all external components are correctly connected and installed.

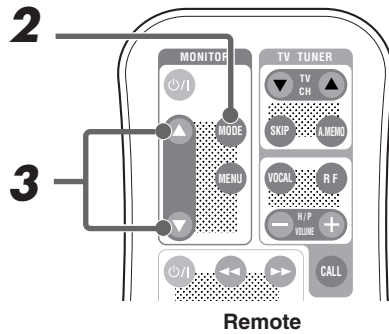
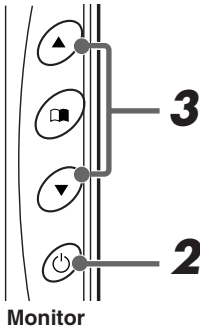

1

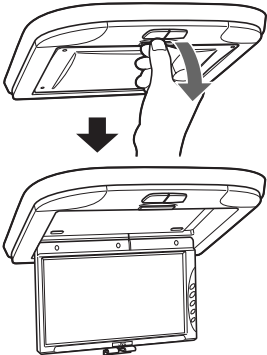

Open the liquid crystal panel.

The monitor turns on.

Note:

If the liquid crystal panel is already open, press the Power button (⏻) on the unit or the Power On/Standby button (⏻/|) on the remote control to turn on the monitor.

CAUTION:

When not in use, close the liquid crystal panel and store it into the compartment; otherwise it may obstruct the visibility through the rearview mirror.

2



Monitor



Remote

Select the input source.

Each time you press the button, the input source changes as follows:

- When KV-C10 is not connected:

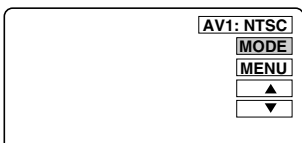
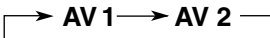

Ex. When "AV 1" is selected

- When KV-C10 is connected:



Ex. When "VIDEO 1" is selected



3



Monitor



Remote

Select the video format—NTSC or PAL, while the indication of the video format is still on the screen.

Each time you press the button, the video format alternates between NTSC (initial setting) and PAL. Select whichever matches to the incoming signals.

Note:

When not using the KV-C10: You can preset the video format separately for “AV 1” and “AV 2.”

4

Play back the external component.

To operate the external components, refer to the manuals for the connected components.

5

Select the external component and adjust the volume on the car receiver.

To check the current input source

On the monitor: Press the Power button (⏻) once.

On the remote: Press the MODE button once.

The on-screen display appears for about 5 seconds.



Monitor



Remote

To turn off the power

Close the liquid crystal panel.

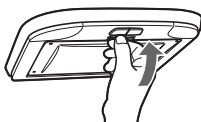

- You can also turn off the power by holding the Power button (⏻) on the unit, or by pressing the Power On/Standby button (⏻/|) on the remote control briefly.



Monitor



Remote



Other Basic Operations

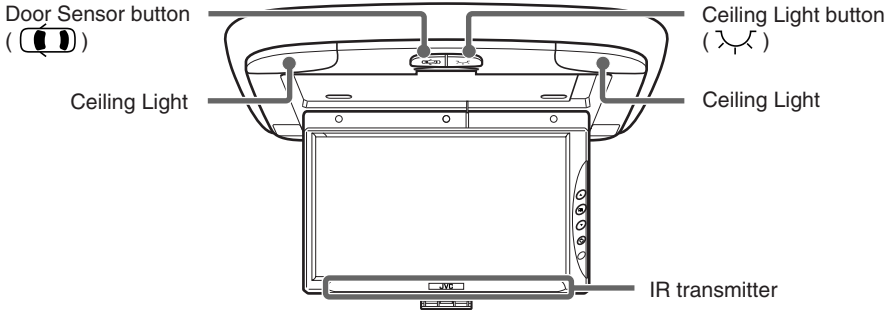

Activating the door sensor

You can activate or deactivate the door sensor by pressing the Door Sensor button (). When you activate the door sensor, the Door Sensor button glows red if the ignition switch of the car is turned to "ON" or "ACC."

- With the door sensor activated, the ceiling lights go on when a door is open.

Turning on or off the ceiling lights

You can turn on or off the ceiling lights on the monitor by pressing the Ceiling Light button ().

Note:

When the Door Sensor button is on, the ceiling lights go off when the door is opened then closed even if the Ceiling Light button has been turned on.

Selecting the RF signals to the receiver

When you use JVC FM modulator KS-IF200 only:

You can listen to playback sounds from the external component through the receiver even if it is equipped with no line input.

- Refer also to the instructions of KS-IF200.

When KV-C10 is connected:

Press the RF button on the remote controller.

Each time you press the button, "RF ON" and "RF OFF" alternate and the sounds you hear through the car speakers change accordingly.

RF ON : Select to listen to the sound of the external component.

RF OFF : Select to listen to the radio (through the receiver).

Using optional cordless headphones

You can use JVC's optional cordless headphones KS-HP1K to listen to the playback sounds of the external component.

Playback sounds of the external component are transmitted through this IR transmitter to the cordless headphones.



Using the Menu

You can make your own adjustments using the Menu.

- For the adjustable items, see the next page.

Basic procedure

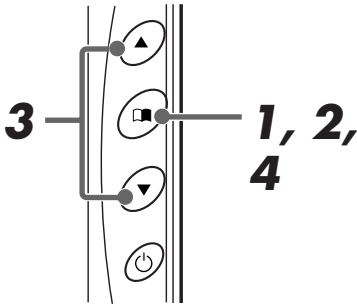

Monitor

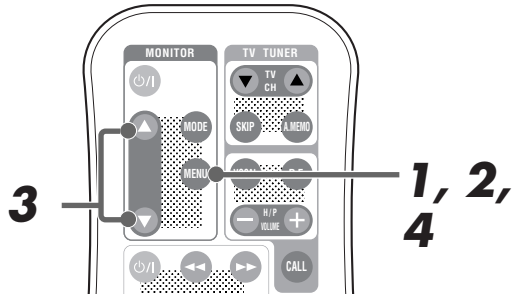

Remote

1



Monitor



Remote

Call up the Menu.

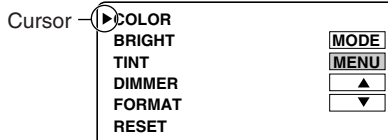

2



Monitor



Remote

Select an item you want to adjust.

Each time you press the button, the cursor moves to the next item.

3

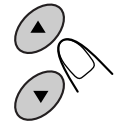

Monitor

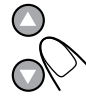

Remote

Adjust the level of the selected item (or select an appropriate setting for the selected item).

- When "RESET" is selected in the above step, the Color, Brightness, and Tint settings are reset.

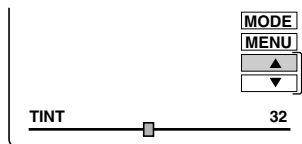

Activated button is highlighted.

Ex: When adjusting Tint

CONTINUED ON THE NEXT PAGE



4



Monitor



Remote

Exit from the Menu.

- Press the button repeatedly until the Menu is erased.

Adjustable items on the menu

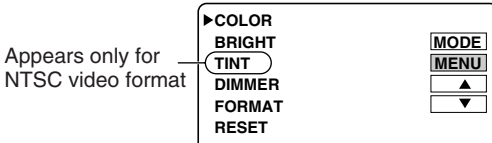

Note:

Menu goes off if no operation is done for about 5 seconds.

COLOR : Adjust the color of the picture—lighter or darker.

- Adjustable range: 0 to 63
- Initial level: 32

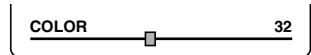

BRIGHT : Adjust this if the picture is too bright or too dark.

- Adjustable range: 0 to 63
- Initial level: 32

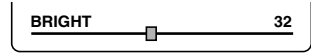

TINT : Adjust this if the human skin color is unnatural.

- Adjustable range: 0 to 63
- Initial level: 32

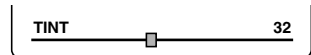

Note:

This can be shown and adjusted when the video format is NTSC.

DIMMER : Activate the dimmer if the inside of the car is too bright to view the picture on the screen.

- Selectable settings: ON/OFF
- Initial setting: OFF





- FORMAT** : Select an appropriate display size.
- Selectable settings: FULL/NORMAL/ZOOM
 - Initial setting: FULL



When viewing 16:9 video signals:

FULL: Pictures are fully shown on the screen.

- The black bars will be shown both at the top and the bottom of the screen.

NORMAL: Pictures are shown at the center of the screen.

ZOOM: Pictures are enlarged on the screen so that no black bars will be shown on the screen. (The entire picture cannot be shown on the screen.)

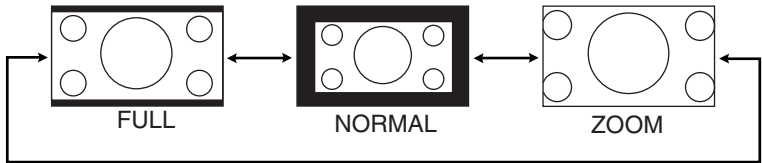

When viewing 4:3 video signals:

FULL: Pictures are enlarged horizontally and are fully shown on the screen.

NORMAL: Pictures are shown at the center of the screen.

- The black bars will be shown at the left and right sides of the screen.

ZOOM: Pictures are enlarged on the screen so that no black bars will be shown on the screen. (The entire picture cannot be shown on the screen.)

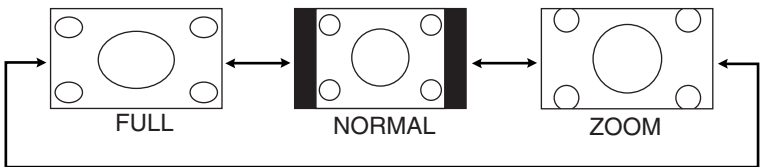

- RESET** : Reset the Color, Brightness, and Tint levels to the initial settings.

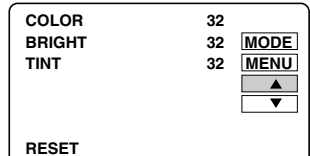



MAINTENANCE

ENGLISH

To prevent damage to the exterior

- Do not apply pesticides, benzene, thinner or other volatile substances to the unit.
The cabinet surface primarily consists of plastic materials.
- Do not wipe with benzene, thinner or similar substances because this will result in discoloration or removal of the paint.
- When a cloth with a cleansing chemical is used, follow the caution points.
 - Do not leave the unit in contact with rubber or vinyl products for long periods of time.
 - Do not use cleansers which have polishing granules because this could damage the surface of the unit.

Clean off dirt by wiping lightly with a soft cloth

When the unit is very dirty, wipe with a well-wrung cloth dipped in a kitchen cleanser (neutral) thinned by water and then go over the same surface with a dry cloth.

(Since there is the possibility of water drops getting inside of the unit, do not directly apply cleanser to the surface.)

Caution:

If water drops or similar wet substances get inside of the monitor via the liquid crystal panel surface, it may cause a malfunction.



TROUBLESHOOTING

What appears to be trouble is not always serious. Check the following points before calling a service center.

Symptoms	Causes	Remedies
• Colored spots (red, blue and green) appear on the screen.	This is a characteristic of liquid crystal panels and is not a malfunction.	See "Note" on page 15.
• No picture appears and sound is not heard.	Correct input mode is not selected.	Select the correct input mode.
• Picture shakes vertically or colors are abnormal.	The video format (NTSC/PAL) is not correct.	Select the correct video format.
• Remote controller does not work. • Cordless headphones (not supplied) do not work.	The battery has lost its charge.	Install a new battery.
	Remote sensor is exposed to strong light.	Do not expose the remote sensor to strong light.

SPECIFICATIONS

WIDE COLOR MONITOR

Display:

9 inch Liquid crystal panel

Number of Pixel:

336,960 pixels (480 vertical × 234 horizontal × 3)

Drive Method:

TFT (Thin Film Transistor) active matrix format

Cordless Audio:

Infrared audio transmitter (Support IR receiver stereo headphones)

L-channel: 2.3 MHz

R-channel: 2.8 MHz

Effective listening angle: 30°

Effective range: 4 m (13.1 ft)

Dimensions (W × H × D):

314 mm × 38 mm × 257 mm
(12-3/8" × 1-1/2" × 10-1/8")

including Shroud

Mass: 1.2 kg (2.7 lbs) including Shroud

MONITOR CONNECTION UNIT

Input

Video: RCA pin × 2 circuits
1 V(p-p), 75 Ω

Audio: RCA pin × 2 circuits
0.5 V(rms)

Tuner: 8-pin DIN connector
(only for JVC's KV-C10)

Output

Display:

13-pin DIN connector

Video: RCA pin × 1 circuit
1 V(p-p), 75 Ω

Audio: RCA pin × 1 circuit
0.5 V(rms)

Dimensions (W × H × D):

108.5 mm × 28.5 mm × 78 mm
(4-5/16" × 1-1/8" × 3-1/8")

excluding projections

Mass: 160 g (0.36 lbs)

GENERAL

Power Requirement

Operating Voltage:

DC 14.4 V (11 V to 16 V allowance)

Grounding System:

Negative ground

Allowable Operating Temperature:

0°C to +40°C (32°F to 104°F)

Allowable Storage Temperature:

-20°C to +80°C (-4°F to 176°F)

Ceiling light bulb: 12 V / 3 W

ACCESSORIES

Metal plate × 1

Shroud × 1

Extension cord × 1

Power cord × 1

Ceiling light cord × 1

Remote controller (with the battery) × 1

Screw (M4 × 5 mm) (M4 × 1/4") × 4

Screw (M4 × 12 mm) (M4 × 1/2") × 4

Design and specifications are subject to change without notice.

Note:

The liquid crystal panel is built with very high precision technology and has at least 99.99% effective image pixels. Be aware that on 0.01% of the panel there may be missing pixels or constantly lit pixels.



JVC

**MOBILE
ENTERTAINMENT**

<http://www.jvcmobile.com>

Visit us on-line for

Technical Support & Customer Satisfaction Survey.

US RESIDENTS ONLY

JVC

VICTOR COMPANY OF JAPAN, LIMITED



EN, SP, FR

© 2003 VICTOR COMPANY OF JAPAN, LIMITED



0303MNMMDWPUN

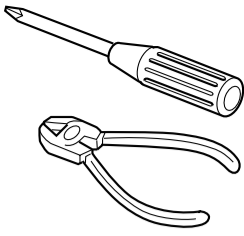

ENGLISH

ESPAÑOL

FRANÇAIS

WARNING

- Installation requires some special knowledge. Do not install the monitor system yourself. Consult a dealer having special knowledge of this kind for safe and reliable installation.
- **DO NOT INSTALL THE MONITOR IN A LOCATION WHICH OBSTRUCTS DRIVING, VISIBILITY OR WHICH IS PROHIBITED BY APPLICABLE LAWS AND REGULATIONS.**
If the monitor is installed in a location which obstructs forward visibility or operation of the air bag or other safety equipment or which interferes with operation of the vehicle, it may cause an accident.
 - **NEVER USE BOLTS OR NUTS FROM THE VEHICLE'S SAFETY DEVICES FOR INSTALLATION.**
If bolts or nuts from the steering wheel, brakes or other safety devices are used for installation of the monitor, it may cause an accident.
 - **ATTACH THE WIRES CORRECTLY.**
If the wiring is not correctly performed, it may cause a fire or an accident. In particular, be sure to run and secure the lead wire so that it does not get tangled with a screw or the moving portion of a seat rail.
 - **USE WITH DC 12 V NEGATIVE GROUND VEHICLES.**
This monitor system is only for use in a DC 12 V negative ground vehicle. It cannot be used in large trucks or diesel vehicles which are DC 24 V vehicles. If it is used in the wrong type of vehicle, it may cause a fire or accident.
 - **To prevent short circuits, we recommend that you disconnect the battery's negative terminal and make all electrical connections before installing the unit. If you are not sure how to install this unit correctly, have it installed by a qualified technician.**
 - **Avoid installing the monitor connection unit in the following places**
 - Where it would hinder your safe driving.
 - Where it would be exposed to direct sunlight or heat directly from the heater or placed in an extremely hot place.
 - Where it would be subject to rain, water splashes or excessive humidity.
 - Where it would be subject to dust.
 - Where it would be positioned on an unstable place.
 - Where it could damage the car's fittings.
 - Where proper ventilation would not be maintained, such as under a floor mat.

CAUTION
Since there may be legal regulations defining the permissible installation locations for the color monitor which differ by country or by state, be sure to install the color monitor in a location complying with any such laws.

ADVERTENCIA

- La instalación requiere cierto conocimiento especial. No instale el sistema del monitor por sí mismo. Para una instalación segura y confiable, consulte con un concesionario que tenga conocimientos especiales en esta área.
- **NO INSTALE EL MONITOR EN UN LUGAR QUE IMPIDA EL MANEJO O LA VISIBILIDAD, NI DONDE LOS PROHIBAN LAS LEYES Y REGLAMENTOS APLICABLES.**
Si el monitor se instala en un lugar que obstruye la visibilidad hacia adelante o la operación de una bolsa de aire u otro equipo de seguridad, o que interfiere con la operación del vehículo, cerca de la palanca de cambios o pedal del freno por ejemplo, podrá causarse un accidente.
 - **NUNCA UTILICE PERNOS O TUERCAS DE LOS DISPOSITIVOS DE SEGURIDAD DEL VEHÍCULO PARA HACER LA INSTALACIÓN.**
Si los pernos o tuercas del volante, frenos u otros dispositivos de seguridad se utilizan para instalar el monitor podrá causarse un accidente.
 - **REALICE EL CABLEADO CORRECTAMENTE.**
Si no se hace bien el cableado puede producirse un incendio o un accidente. En particular, asegúrese de instalar el cable conductor para que éste no quede enredado en un tornillo ni en la parte móvil del rail del asiento.
 - **UTILICE EL MONITOR EN VEHÍCULOS DE 12 V CC CON PUESTA A TIERRA NEGATIVA.**
Este monitor ha sido diseñado para ser utilizado solamente en vehículos de 12 V CC con puesta a tierra negativa. No puede utilizarse en camiones grandes ni vehículos diesel de 24 V CC. Si se utiliza en el tipo equivocado de vehículo se puede causar un incendio o accidente.
 - **Para evitar cortocircuitos, se recomienda desconectar el terminal negativo de la batería y realizar todas las conexiones eléctricas antes de instalar la unidad. Si tiene dudas sobre cómo realizar la instalación correctamente, déjela en manos de un técnico cualificado.**
 - **Evite instalar la unidad de conexión del monitor en los siguientes lugares:**
 - Donde pueda constituir un obstáculo para la conducción.
 - Donde pueda quedar expuesto a la luz solar directa o al calor directo de un calefactor, o en un lugar muy caliente.
 - Donde pueda mojarse debido a la lluvia, etc., o en un lugar excesivamente húmedo.
 - En un lugar polvoriento.
 - En un sitio inestable.
 - Donde pueda producir daños en los herrajes del automóvil.
 - En lugares donde no pueda obtenerse una ventilación adecuada, como debajo de la alfombra del piso.

PRECAUCION
Dependiendo de los estados, pueden haber reglamentos locales que determinan los lugares de instalación permisibles para el monitor de color; por lo tanto, asegúrese de instalar el monitor en un sitio que cumpla con tales reglamentos.

AVERTISSEMENT

- L'installation nécessite certaines connaissances spéciales. N'installez pas le moniteur vous-même. Consultez un revendeur possédant les connaissances spéciales nécessaires pour une installation correcte et sûre.
- **N'INSTALLEZ PAS LE MONITEUR DANS UN ENDROIT QUI GÊNE LA CONDUITE, LA VISIBILITÉ OU QUI EST INTERDIT PAR LE CODE DE LA ROUTE ET LES RÈGLEMENTS.**
Si le moniteur était installé à un emplacement gênant la visibilité avant, ou le déploiement du sac à air, et autres dispositifs de sécurité, ou à un emplacement gênant pour la conduite du véhicule, comme près du levier des vitesses ou de la pédale du frein, cela risquerait de provoquer des accidents.
 - **NE JAMAIS UTILISER POUR L'INSTALLATION DES BOULONS OU DES ÉCROUS PROVENANT DES DISPOSITIFS DE SÉCURITÉ DU VÉHICULE.**
Si l'on utilisait pour l'utilisation du moniteur des boulons et des écrous cannibalisés du volant, des freins ou autres dispositifs de sécurité, cela risquerait de provoquer des accidents.
 - **ATTACHER LES CORDONS CORRECTEMENT.**
Si le câblage n'est pas exécuté correctement, cela risque de provoquer un incendie ou autre accident. Veiller, en particulier, à tirer et attacher les fils en sorte qu'ils ne s'accrochent pas à une vis ou ne se coincent dans les parties mobiles des rails des sièges.
 - **USAGE SUR LES VÉHICULES DE 12 V CC AVEC NÉGATIF À LA MASSE.**
Ce moniteur ne peut être utilisé que sur les véhicules de 12 V CC avec négatif à la masse. Il ne peut pas être utilisé sur les gros camions ou les véhicules diesel de 24 V CC. S'il était utilisé sur un type de véhicule inadéquat cela risquerait de provoquer un incendie ou autres accidents.
 - **Pour éviter les courts-circuits, nous recommandons que vous déconnectiez la borne négative de la batterie et réalisez toutes les connexions électriques avant d'installer l'appareil. Si vous n'êtes pas sûr de savoir comment installer cet appareil correctement, faites-le installer par un technicien qualifié.**
 - **Évitez d'installer l'unité de connexion du moniteur dans les endroits suivants:**
 - Où il peut gêner la conduite de la voiture.
 - Où il est exposé à la lumière directe du soleil, à la chaleur directe du chauffage ou placé dans un endroit très chaud.
 - Où il est sujet à la pluie, aux éclaboussures ou à une humidité excessive.
 - Où il est sujet à la poussière.
 - Où il est positionné dans un endroit instable.
 - Où il peut endommager les accessoires de la voiture.
 - Où une ventilation correcte ne peut pas être maintenue, comme sous un tapis de sol.

ATTENTION
Il peut y avoir des réglementations définissant les emplacements d'installation autorisés pour un moniteur couleur et celles-ci peuvent varier d'une région à l'autre. Assurez-vous d'installer le moniteur dans un endroit conforme à ces lois.

Parts list for installation and connection
The following parts are provided with this unit. After checking them, please set them correctly.

Lista de piezas para instalación y conexión
Con esta unidad se suministran las siguientes piezas. Después de inspeccionarlas, colóquelas correctamente.

Liste des pièces pour l'installation et raccordement
Les pièces suivantes sont fournies avec cet appareil. Après vérification, veuillez les placer correctement.

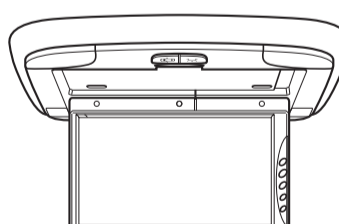

Wide color monitor (center unit and shroud)
Monitor color de pantalla ancha (unidad central y refuerzo)
Moniteur couleur à écran large (unité centrale et socle de montage au plafond)

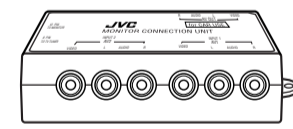

Monitor connection unit
Unidad de conexión del monitor
Unité de connexion du moniteur

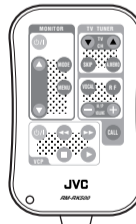

Remote controller with a battery (CR2025) installed
Unidad de control remote con una pila instalada (CR2025)
Télécommande avec une pile en place (CR2025)

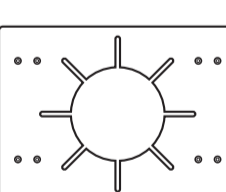

Metal plate
Placa metálica
Plaque métallique

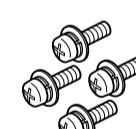

Screws (M4 x 5 mm) (M4 x 1/4")
Tornillos (M4 x 5 mm) (M4 x 1/4 pulgada)
Vis (M4x 5 mm) (M4 x 1/4 po.)

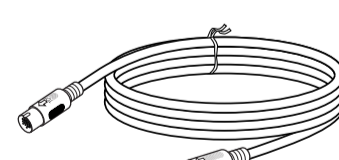

Extension cord (4 m) (13 ft)
Cordón prolongador (4 m) (13 pies)
Cordon prolongateur (4 m) (13 pieds)

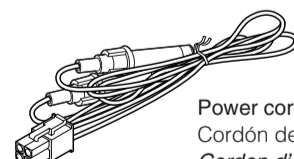

Power cord
Cordón de alimentación
Cordon d'alimentation

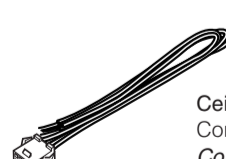

Ceiling light cord
Cordón de la luz del techo
Cordon de plafonnier

TROUBLESHOOTING

- **The fuse blows.**
* Are the red and black leads connected correctly?
- **Power cannot be turned on.**
* Is the yellow lead connected?
- **Picture does not come on screen.**
* Is the correct input selected?

LOCALIZACION DE AVERIAS

- **El fusible se quema.**
* ¿Están los conductores rojo y negro correctamente conectados?
- **No es posible conectar la alimentación.**
* ¿Está el cable amarillo conectado?
- **La imagen no aparece en la pantalla.**
* ¿Se ha seleccionado la entrada correcta?

EN CAS DE DIFFICULTÉS

- **Le fusible saute.**
* Les fils rouge et noir sont-ils raccordés correctement?
- **L'appareil ne peut pas être mise sous tension.**
* Le fil jaune est-elle raccordée?
- **Aucune image n'apparaît sur l'écran.**
* L'entrée correcte est-elle choisie?

INSTALLATION

- The following illustration shows a typical installation. However, you should make adjustments corresponding to your specific car. If you have any questions or require information regarding installation kits, consult your JVC car audio dealer or a company supplying kits.

INSTALACIÓN

- La siguiente ilustración muestra una instalación típica. Sin embargo usted deberá efectuar los ajustes correspondientes a su automóvil. Si tiene alguna pregunta o necesita información acerca de las herramientas para instalación, consulte con su concesionario de JVC de equipos de audio para automóviles o a una compañía que suministra tales herramientas.

INSTALLATION

- L'illustration suivante est un exemple d'installation typique. Cependant, vous devez faire les ajustements correspondant à votre voiture particulière. Si vous avez des questions ou avez besoin d'information sur des kits d'installation, consulter votre revendeur d'autoradios JVC ou une compagnie d'approvisionnement.

Mounting the color monitor

Installation procedure varies among different cars. The following is an example.

It is recommended to have the monitor system installed by a qualified technician.

Before mounting the monitor to the ceiling:

- Perform the required external connections first.

Montaje del monitor de color

El procedimiento de instalación varía según los diferentes vehículos. Lo siguiente es sólo un ejemplo.

Se recomienda que el sistema de monitor sea instalado por un técnico cualificado.

Antes de instalar el monitor en el techo:

- Efectúe primero las conexiones externas requeridas.

Montage du moniteur couleur

La procédure d'installation varie d'une voiture à l'autre. La procédure qui suit est un exemple.

Il est recommandé de faire installer le système de moniteur par un technicien qualifié.

Avant de fixer le moniteur au plafond:

- Réalisez d'abord les connexions extérieures nécessaires.

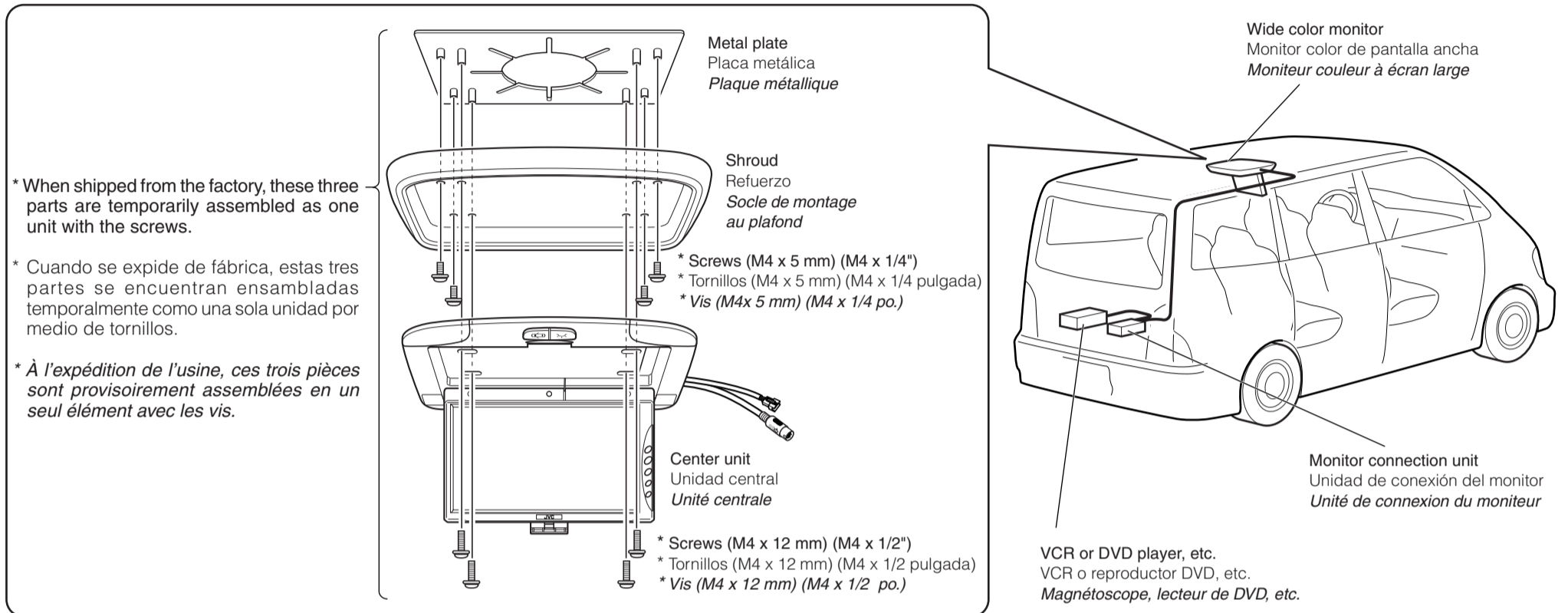

Replacing the ceiling light bulbs / Reemplazo de las bombillas de las luces del techo / Remplacement des ampoules du plafonnier

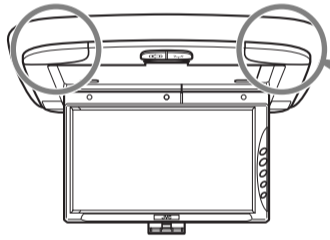

To remove the ceiling light cover, proportionally loosen the screws fixing the center unit.
Para retirar la tapa de la luz del techo, afloje proporcionalmente los tornillos de fijación de la unidad central.
Pour retirer le couvercle du plafonnier desserrez proportionnellement les vis fixant l'unité centrale.

1

Ceiling light cover
Tapa de la luz del techo
Couvercle de plafonnier

2

Ceiling light bulb
Bombilla de la luz del techo
Ampoule de plafonnier

ELECTRICAL CONNECTIONS

To prevent short circuits, we recommend that you disconnect the battery's negative terminal and make all electrical connections before installing the unit. If you are not sure how to install this unit correctly, have it installed by a qualified technician.

Note:

This unit is designed to operate on **12 V DC, NEGATIVE ground electrical systems**. If your vehicle does not have this system, a voltage inverter is required, which can be purchased at JVC car audio dealers.

- Replace the fuse with one of the specified ratings. If the fuse blows frequently, consult your JVC car audio dealer.

CONEXIONES ELECTRICAS

Para evitar cortocircuitos, recomendamos que desconecte el terminal negativo de la batería y que efectúe todas las conexiones eléctricas antes de instalar la unidad. Si usted no está seguro de cómo instalar correctamente la unidad, hágala instalar por un técnico cualificado.

Nota:

Esta unidad está diseñada para funcionar con **12 V de CC, con sistemas eléctricos de masa NEGATIVA**. Si su vehículo no posee este sistema, será necesario un inversor de tensión, que puede ser adquirido en los concesionarios de JVC de equipos de audio para automóviles.

- Reemplace el fusible por uno con la corriente especificada. Si el fusible se quemase frecuentemente, consulte con su concesionario car audio de JVC.

RACCORDEMENTS ELECTRIQUES

Pour éviter tout court-circuit, nous vous recommandons de débrancher la borne négative de la batterie et d'effectuer tous les raccordements électriques avant d'installer l'appareil. Si l'on n'est pas sûr de pouvoir installer correctement cet appareil, le faire installer par un technicien qualifié.

Remarque:

Cet appareil est conçu pour fonctionner sur des sources de courant continu de **12 V à masse NEGATIVE**. Si votre véhicule n'offre pas ce type d'alimentation, il vous faut un convertisseur de tension, que vous pouvez acheter chez un revendeur d'autoradios JVC.

- Remplacer le fusible par un de la valeur précisée. Si le fusible saute souvent, consulter votre revendeur d'autoradios JVC.

Monitor connection unit / Unidad de conexión del monitor / Unité de connexion du moniteur

Front
Lado delantero
Avant

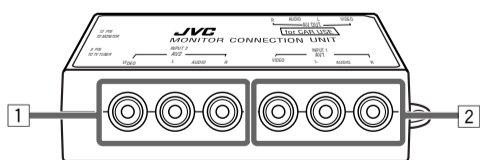

Back
Lado trasero
Arrière

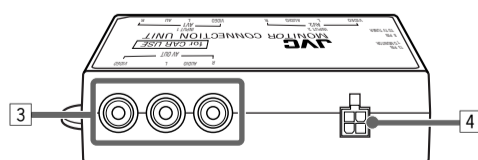

Side
Lateral
Côté

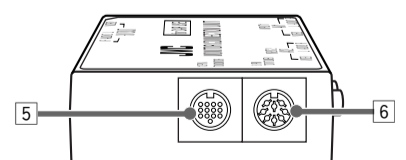

- AV 2 (INPUT 2) jacks
 - VIDEO/AUDIO L (left)/AUDIO R (right)
- AV 1 (INPUT 1) jacks
 - VIDEO/AUDIO L (left)/AUDIO R (right)
- AV OUT jacks
 - VIDEO/AUDIO L (left)/AUDIO R (right)
- Power Supply connector
- TO MONITOR (13 PIN) connector
- TO TV TUNER (8 PIN) connector

- Jacks AV 2 (INPUT 2)
 - VIDEO/AUDIO L (izquierdo)/AUDIO R (derecho)
- Jacks AV 1 (INPUT 1)
 - VIDEO/AUDIO L (izquierdo)/AUDIO R (derecho)
- Jacks AV OUT
 - VIDEO/AUDIO L (izquierdo)/AUDIO R (derecho)
- Conector de la fuente de alimentación
- Conector TO MONITOR (13 clavijas)
- Conector TO TV TUNER (8 clavijas)

- Prises AV 2 (INPUT 2)
 - VIDEO/AUDIO L (gauche)/AUDIO R (droit)
- Prises AV 1 (INPUT 1)
 - VIDEO/AUDIO L (gauche)/AUDIO R (droit)
- Prises AV OUT
 - VIDEO/AUDIO L (gauche)/AUDIO R (droit)
- Connecteur d'alimentation
- Connecteur TO MONITOR (13 PIN)
- Connecteur TO TV TUNER (8 PIN)

Typical Connections / Conexiones típicas / Raccordements typiques

Before connecting: Check the wiring in the vehicle carefully. Incorrect connection may cause serious damage to this unit. The leads of the power cord and the ceiling light cord and those of the connector from the car body may be different in color.

Antes de la conexión: Verifique atentamente el conexionado del vehículo. Una conexión incorrecta podría producir daños graves en la unidad. Los conductores del cordón de alimentación y el cordón de la luz del techo y de los conectores procedentes de la carrocería del vehículo podrían ser diferentes en color.

Avant de commencer la connexion: Vérifiez attentivement le câblage du véhicule. Une connexion incorrecte peut endommager sérieusement l'appareil. Les fils du cordon d'alimentation et du cordon du plafonnier et ceux du connecteur provenant de la voiture peuvent être de couleur différente.

Power supply connection

Conexión de la fuente de alimentación

Connexion de l'alimentation

- 1 Connect the colored leads of the power cord in the following sequence.
 - ① Black: ground
 - ② Yellow: to car battery (constant 12 V)
 - ③ Red: to an accessory terminal
 - ④ Blue: to remote control lead of the external component (such as KS-IF200).
- 2 Finally connect the wiring harness to the unit.

- 1 Conecte los conductores de color del cordón de alimentación en la secuencia siguiente.
 - ① Negro: a tierra
 - ② Amarillo: a la batería del automóvil (12 V constantes)
 - ③ Rojo: a un terminal de accesorio
 - ④ Azul: para el conductor del controlador remoto del componente externo (como por ejemplo KS-IF200).
- 2 Por último, conecte el cable de alimentación a la unidad.

- 1 Connectez les fils de couleur du cordon du plafonnier dans l'ordre suivant.
 - ① Noir: à la masse
 - ② Jaune: à la batterie de la voiture (12 V constant)
 - ③ Rouge: à la prise accessoire
 - ④ Bleu: au fil de télécommande de l'appareil extérieur (tel que le KS-IF200).
- 2 Finalement, connectez le faisceau de fils à l'appareil.

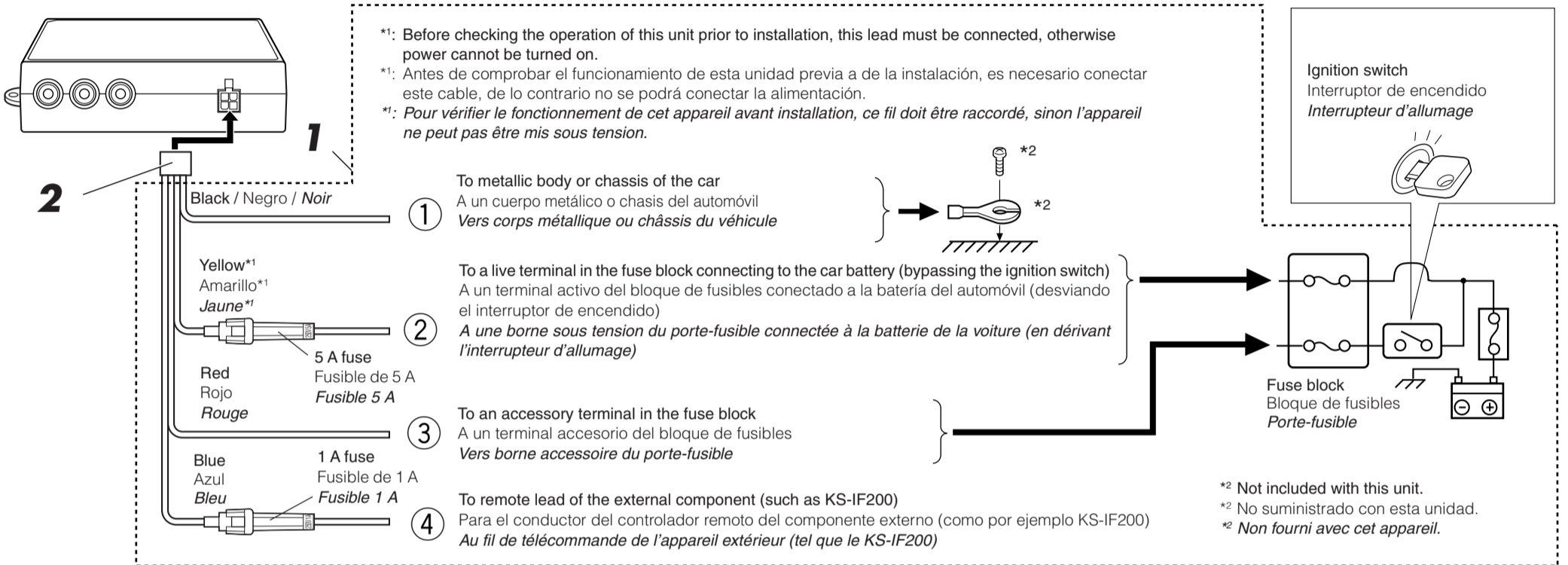

Ceiling light connection

Conexión de la luz del techo

Connexion de plafonnier

- 1 Connect the colored leads of the ceiling light cord in the following sequence.
 - ① Black: ground (GND)
 - ② Yellow: to car battery (constant 12 V) (BATTERY B+)
 - ③ Red: to an accessory terminal (ACC)
 - ④ Grey: to the door sensor (DOOR SW)

- 1 Conecte los conductores de color de la luz del techo en la secuencia siguiente.
 - ① Negro: a tierra (GND)
 - ② Amarillo: a la batería del automóvil (12 V constantes) (BATTERY B+)
 - ③ Rojo: a un terminal de accesorio (ACC)
 - ④ Gris: al sensor de la puerta (DOOR SW)

- 1 Connectez les fils de couleur du cordon du plafonnier dans l'ordre suivant.
 - ① Noir: à la masse (GND)
 - ② Jaune: à la batterie de la voiture (12 V constant) (BATTERY B+)
 - ③ Rouge: à la prise accessoire (ACC)
 - ④ Gris: au capteur de porte (DOOR SW)

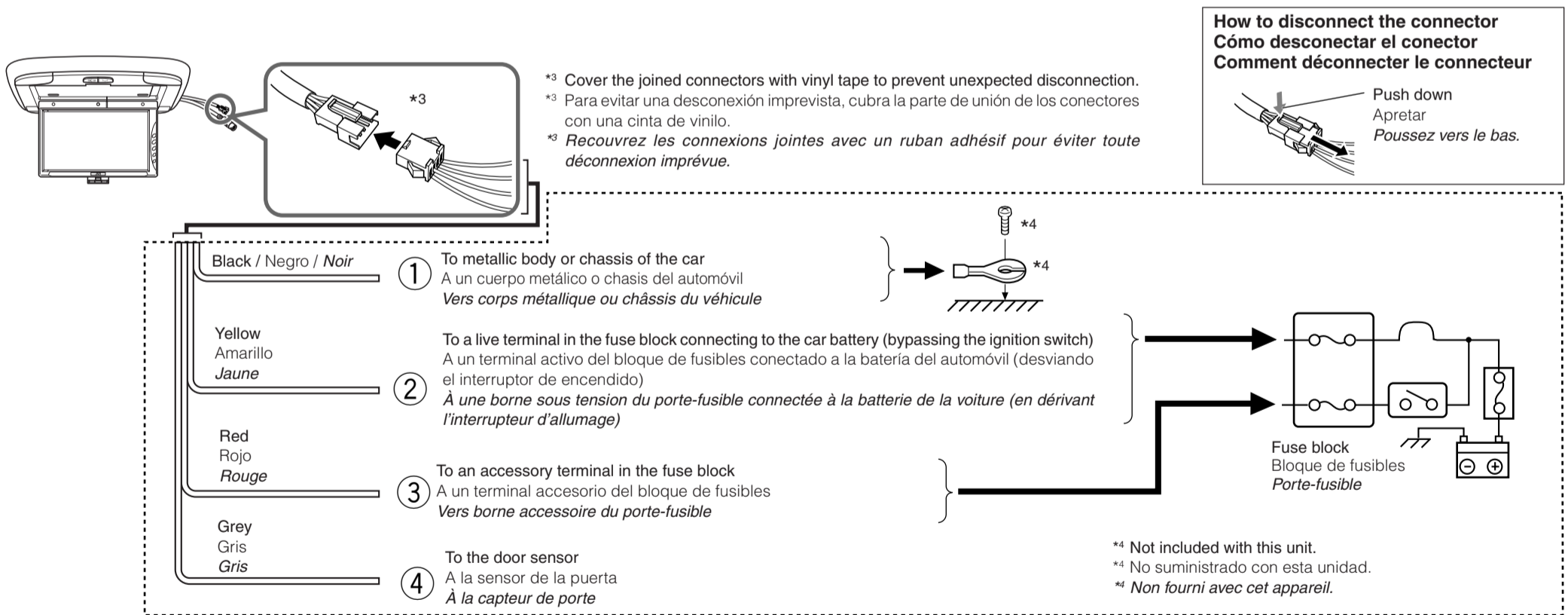

Connecting the leads / Conexión de los conductores / Raccordement des fils

Twist the core wires when connecting. Retuerce los alambres de alma para conectarlos.
Torsader les âmes des fils en les raccordant.

Solder the core wires to connect them securely. Suelde los alambres de alma para conectarlos con firmeza.
Souder les âmes des fils pour les raccorder entre eux de façon sûre.

CAUTION / PRECAUCION / ATTENTION:

- To prevent short-circuit, cover the terminals of the UNUSED leads with insulating tape.
- Para evitar cortocircuitos, cubra los cables NO UTILIZADOS con cinta aislante.
- Pour éviter les court-circuits, couvrir les bornes des fils qui ne sont PAS utilisés avec de la bande isolante.

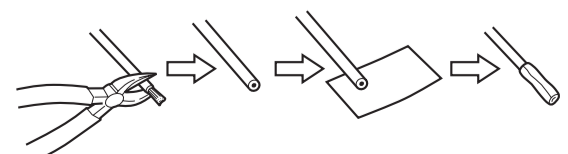

CONNECTING THE EXTERNAL COMPONENTS

Connect the monitor to TO MONITOR jack. If the monitor cord is not long enough for connection, use the extension cord supplied with the unit.

The monitor connection unit provides 2 input circuits and 1 output circuit. Connect one or two playback sources to AV 1 (INPUT 1) and/or AV 2 (INPUT 2) and connect reproducing components, such as a car receiver, to AV OUT.

CONEXION DE LOS COMPONENTES EXTERNOS

Conecte el monitor al jack TO MONITOR. Utilice el cable prolongador suministrado con la unidad cuando la longitud del cable del monitor no sea suficiente para la conexión.

La unidad de conexión monitor provee 2 circuitos de entrada y 1 circuito de salida. Conecte uno o dos fuentes de reproducción a AV 1 (INPUT 1) y/o AV 2 (INPUT 2) y conecte los componentes de reproducción, como un receptor de audio para automóvil, a AV OUT.

CONNEXION DES APPAREILS EXTÉRIEURS

Connectez le moniteur à la prise TO MONITOR. Si le cordon du moniteur n'est pas assez long pour la connexion, utilisez le cordon prolongateur fourni avec cet appareil.

Cet unité de connexion du moniteur possède 2 circuits d'entrée et un circuit de sortie. Connectez une ou deux sources de lecture à la prise AV 1 (INPUT 1) et/ou à la prise AV 2 (INPUT 2) et connectez un appareil de traitement du son tel qu'un récepteur d'autoradio à la prise AV OUT.

• When not using the mobile TV tuner system KV-C10 / Cuando no se utiliza el sistema de sintonizador de TV móvil KV-C10 / Lorsque vous n'utilisez pas le système de tuner de télévision mobile KV-C10

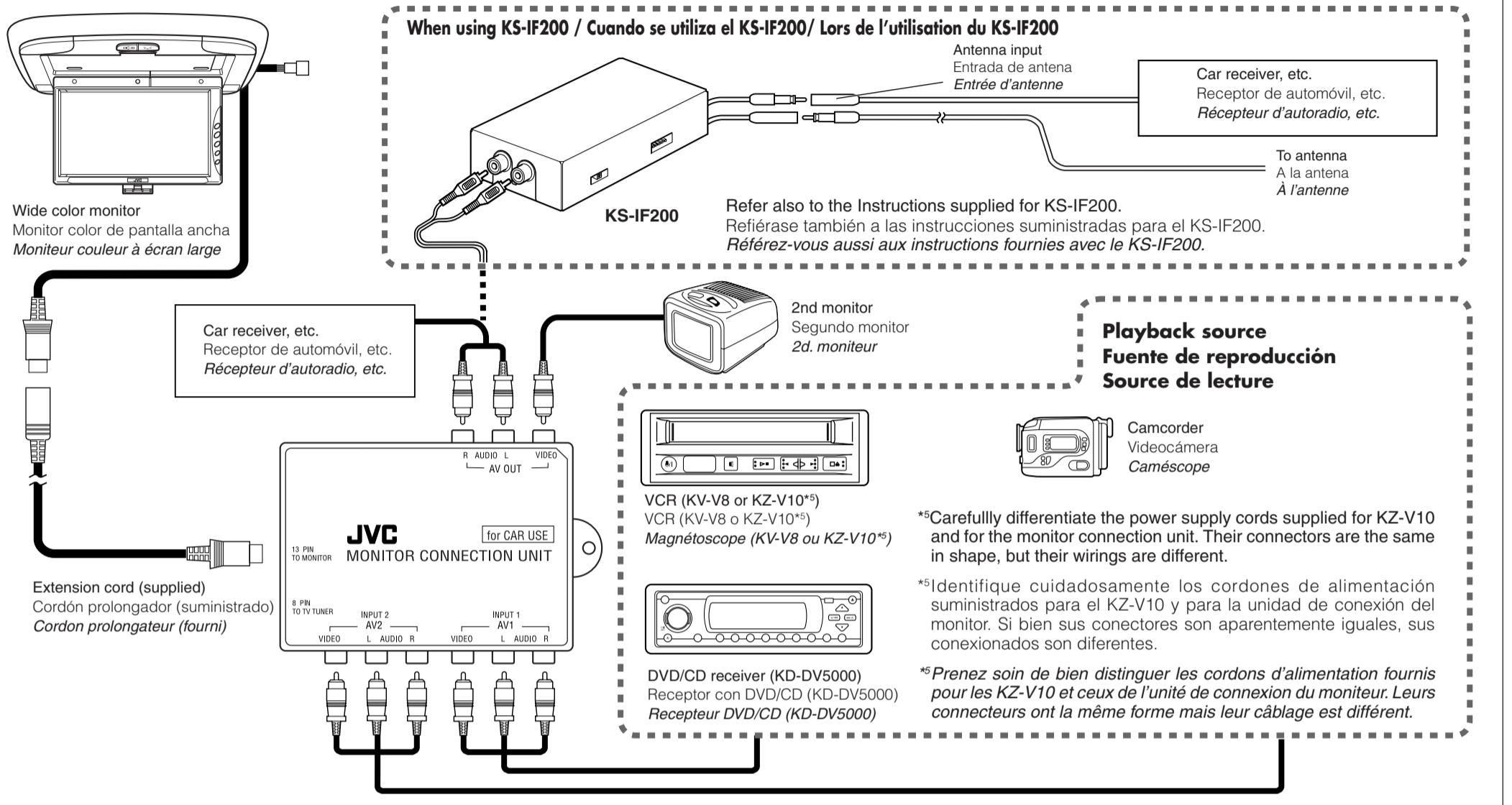

• When using the mobile TV tuner system KV-C10 / Cuando se utiliza el sistema de sintonizador de TV móvil KV-C10 / Lors de l'utilisation du système de tuner de télévision mobile KV-C10

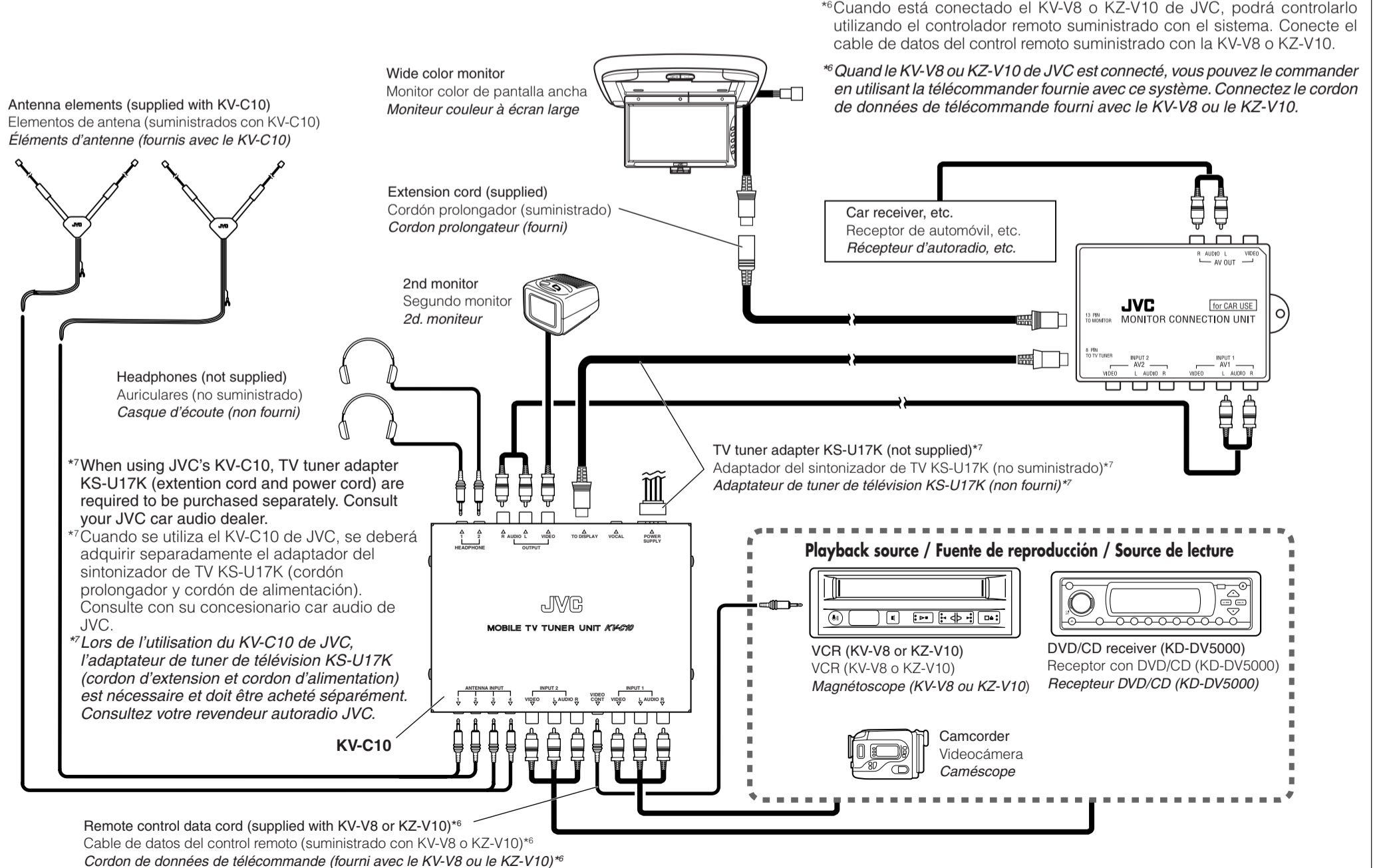

JVC



9-INCH WIDE COLOR MONITOR

9"-BREITBILD-FARBMONITOR

MONITEUR COULEUR À ÉCRAN LARGE DE 9 POUCES

9-INCH BREED KLEURENMONITOR

KV-MR9000

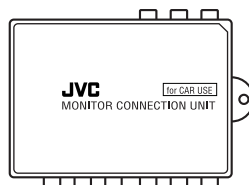
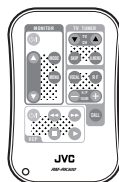
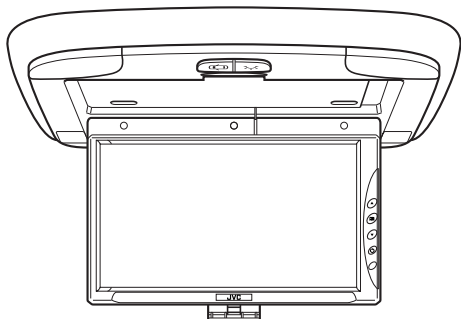

For installation and connections, refer to the separate manual.

Für den Einbau und die Anschlüsse siehe das eigenständige Handbuch.

Pour l'installation et les raccordements, référez-vous au manuel séparé.

Bijzonderheden over de installatie en aansluiting van het apparaat vindt u in de desbetreffende handleiding.

* This system cannot receive television broadcasts and is primarily designed for use with a VCR or a DVD player. Use the separately sold mobile TV tuner unit KV-C10 for optional television broadcast reception.

* Dieses System kann keine Fernsehsignale empfangen und wurde in erster Linie für die Verwendung mit einem Videorecorder oder einem DVD-Spieler konzipiert. Verwenden Sie den separat erhältlichen Fernsehtuner KV-C10, um Fernsehsignale zu empfangen.

* Ce système ne peut pas recevoir les émissions de télévision et il est essentiellement conçu pour l'utilisation avec un magnéscope ou un lecteur de DVD. Utilisez le module de tuner de télévision mobile KV-C10 vendu séparément afin de pouvoir recevoir les émissions de télévision.

* Met dit systeem kunt u geen televisie-uitzendingen ontvangen. Dit systeem is voornamelijk ontworpen voor het gebruik met een videorecorder of een DVD-speler. Gebruik de los verkrijgbare draagbare, KV-C10 TV-tuner voor ontvangst van televisie-uitzendingen.

INSTRUCTIONS

BEDIENUNGSANLEITUNG
MANUEL D'INSTRUCTIONS
GEBRUIKSAANWIJZING

ENGLISH

DEUTSCH

FRANÇAIS

NETERLANDS

WARNING:

TO PREVENT FIRE OR SHOCK HAZARD, DO NOT EXPOSE THIS UNIT TO RAIN OR MOISTURE.

CAUTION:

This monitor system should be used with DC 12V only. To prevent electric shocks and fire hazards, DO NOT use any other power source.

Installation requires some special knowledge.

Do not install the monitor system yourself. Consult a dealer having special knowledge of this kind for safe and reliable installation.

WARNINGS

- DO NOT INSTALL THE MONITOR IN A LOCATION WHICH OBSTRUCTS DRIVING, VISIBILITY OR WHICH IS PROHIBITED BY APPLICABLE LAWS AND REGULATIONS.
- THERE MAY BE LEGAL REGULATIONS DEFINING THE PERMISSIBLE INSTALLATION LOCATIONS FOR THE DISPLAY UNIT WHICH DIFFER BY COUNTRY OR BY STATE. BE SURE TO INSTALL THE DISPLAY UNIT IN A CORRECT LOCATION ACCORDING TO SUCH LAWS.
- DO NOT INSTALL THE MONITOR IN A LOCATION WHICH OBSTRUCTS THE OPERATION OF AN AIR BAG.
- THE DRIVER MUST NOT OPERATE THE MONITOR SYSTEM WHILE DRIVING.
OPERATING THE MONITOR WHILE DRIVING MAY LEAD TO CARELESSNESS AND CAUSE AN ACCIDENT.
* STOP YOUR VEHICLE IN A SAFE LOCATION WHEN OPERATING THE MONITOR.
- THE DRIVER MUST NOT WATCH THE TELEVISION OR VIDEOS WHILE DRIVING.
IF THE DRIVER WATCHES THE TELEVISION OR A VIDEO WHILE DRIVING, IT MAY LEAD TO CARELESSNESS AND CAUSE AN ACCIDENT.
- WHEN LIGHTNING OCCURS, DO NOT TOUCH THE ANTENNA WIRE OR THE TELEVISION.
TOUCHING THE ANTENNA WIRE OR THE TELEVISION UNDER SUCH CONDITIONS MAY CAUSE ELECTROCUTION.
- KEEP THE MONITOR AT AN APPROPRIATE SOUND LEVEL WHILE DRIVING.
DRIVING WITH THE SOUND AT A LEVEL THAT PREVENTS YOU FROM HEARING SOUNDS OUTSIDE OF AND AROUND THE VEHICLE MAY CAUSE AN ACCIDENT.
- ASK A TRAINED TECHNICIAN TO INSTALL THE MONITOR SYSTEM.
INSTALLATION AND WIRING REQUIRE TRAINING AND EXPERIENCE.
* TO BE SAFE, ASK THE SALES OUTLET WHERE YOU PURCHASED THE MONITOR SYSTEM TO PERFORM THE INSTALLATION.
- BE SURE NOT TO LET THE MONITOR FALL OR BE STRONGLY IMPACTED SINCE THIS MAY CAUSE A MALFUNCTION OR FIRE.
- DO NOT USE THE MONITOR WITH THE ENGINE OFF.
WATCHING THE MONITOR WITH THE ENGINE OFF WILL CONSUME BATTERY POWER AND MAY PREVENT THE ENGINE FROM STARTING.
- DO NOT USE ANY CEILING LIGHT BULBS OTHER THAN SPECIFIED FOR THIS UNIT (12 V, 3 W).
FAILING TO DO SO MAY POSSIBLY CAUSE FIRE.
- WHEN NOT IN USE, CLOSE THE LIQUID CRYSTAL PANEL AND STORE IT INTO THE COMPARTMENT.

Thank you for purchasing a JVC product. Please read all instructions carefully before operation, to ensure your complete understanding and to obtain the best possible performance from the unit.

CONTENTS

PRECAUTIONS	4
CONTROLS AND FEATURES	5
Wide color monitor	5
Remote controller	6
Replacing the battery	7

BASIC OPERATIONS	8
Other basic operations	10
Activating the door sensor	10
Turning on or off the ceiling lights	10
Selecting the RF signals to the receiver	10
Using optional cordless headphones	10

ADJUSTMENTS	11
Using the Menu	11
Basic procedure	11
Adjustable items on the menu	12

MAINTENANCE	14
TROUBLESHOOTING	14
SPECIFICATIONS	15



BEFORE USE

* For safety....

- Do not raise the volume level too much, as this will block outside sounds, making driving dangerous.
- Stop the car before performing any complicated operations.

* Temperature inside the car....

If you have parked the car for a long time in hot or cold weather, wait until the temperature in the car becomes normal before operating the unit.



PRECAUTIONS

ENGLISH

Cautions for handling the liquid crystal panel

Do not expose the liquid crystal display to direct sunlight.

- Storage temperature range: $-20\text{ }^{\circ}\text{C}$ to $+80\text{ }^{\circ}\text{C}$

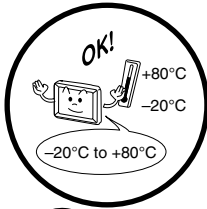

When the liquid crystal panel reaches high temperatures or low temperatures, chemical changes occur within the liquid crystal panel which may cause it to malfunction.

The red spots, blue spots and green spots on the panel surface are a normal characteristic of liquid crystal panels, and not a problem.

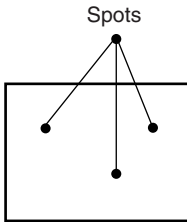

The liquid crystal panel is built with very high precision technology and has at least 99.99% effective image pixels. Be aware that on 0.01% of the panel there may be missing or constantly lit pixels.

Do not drop the liquid crystal display or strike it sharply.

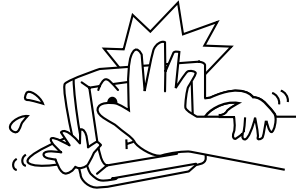

When the temperature is very cold or very hot, the image may not appear clearly or may move slowly.

The image may not be synchronized with the sound or the image quality may decline in such environments. Note that this is not a malfunction or problem.

- Usage temperature range: $0\text{ }^{\circ}\text{C}$ to $+40\text{ }^{\circ}\text{C}$



$0\text{ }^{\circ}\text{C}$ or colder

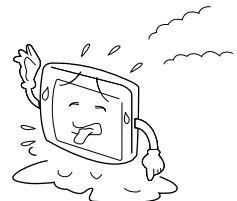

$40\text{ }^{\circ}\text{C}$ or hotter



Wide color monitor

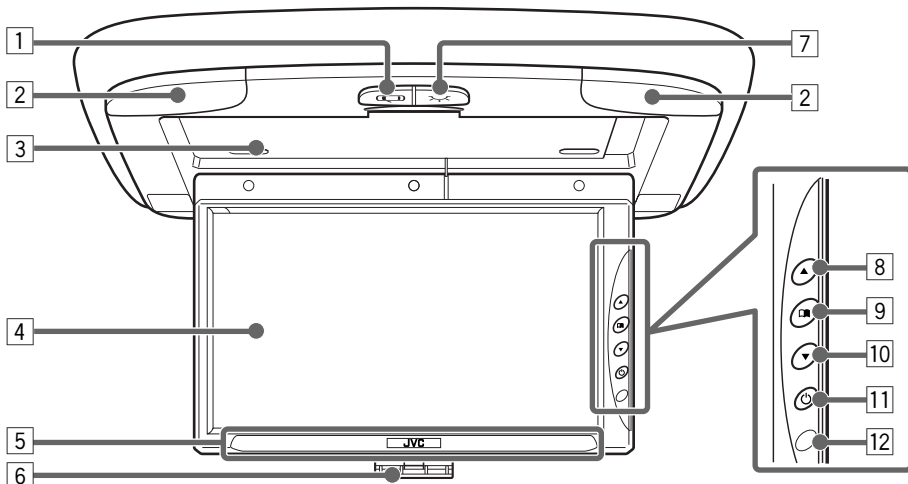

1 Door Sensor button ()

Activates or deactivates the door sensor which turns on the ceiling light when a door is open.

- When the door sensor is turned on, this button glows red.

2 Ceiling lights

3 Screen compartment

While not in use, close the screen and store it in this compartment.

4 Screen (Liquid crystal panel)

- When you open the screen, the monitor automatically turns on.
- When you close it, the monitor automatically turns off.

5 IR transmitter

• See “Specifications” for cordless headphones.

It is recommended to use JVC’s cordless headphones KS-HP1K.

6 Screen hook

- Release from the screen compartment to use the monitor.
- After using the monitor, close the screen, and hook to the screen compartment.

7 Ceiling Light button ()

Turns on or off the ceiling lights.

8 Up button ()

Increase the adjustment level of (or select an appropriate setting for) the item selected by the Menu button.

9 Menu button ()

Select an adjustment item.

10 Down button ()

Decrease the adjustment level of (or select an appropriate setting for) the item selected by the Menu button.

11 Power button ()

- Press to turn on the power.
Each time you press the button, the input mode changes when the power is on.
- Press and hold to turn off the power.

12 Remote sensor

Aim at this area when operating the monitor from the remote controller.

Note:

When you watch the screen at an angle, the picture might not be clear. This is not a malfunction. The finest picture can be seen when you watch the screen straight-on.

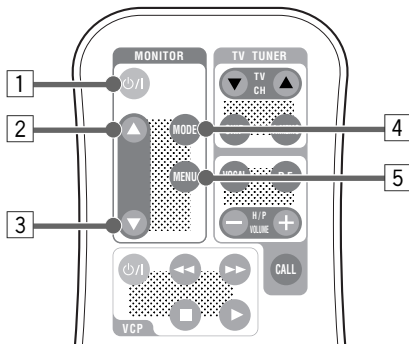
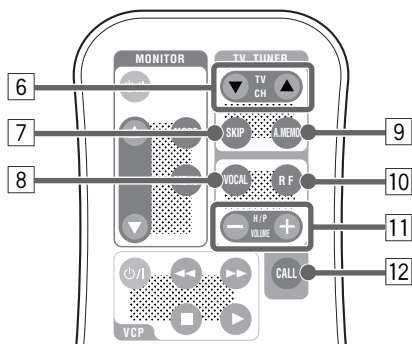
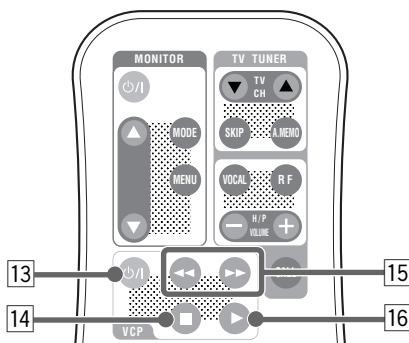
**Remote controller RM-RK500****Monitor section****TV tuner section****Video cassette player section****Monitor section**

- 1 **Power On/Standby button (⏻/⏻)**
Turn on or off the monitor system.
- 2 **Up button (▲)**
Increase the adjustment level of (or select an appropriate setting for) the item selected by the MENU button.
- 3 **Down button (▼)**
Decrease the adjustment level of (or select an appropriate setting for) the item selected by the MENU button.
- 4 **MODE button**
Each time you press the button, the input mode changes.
- 5 **MENU button**
Call up or erase the Menu screen.

TV tuner section

The following buttons can be used for operating JVC's KV-C10.

• For specific operations, refer to the instructions for the KV-C10.

- 6 **TV CH buttons (▲/▼)**
- 7 **SKIP button**
- 8 **VOCAL button**
- 9 **A.MEMO (auto memory) button**
- 10 **RF (radio frequency) button**
- 11 **H/P (headphones) VOLUME buttons (+/-)**
- 12 **CALL button**

Video cassette player (VCP) section

The following buttons can be used for operating JVC's KV-V8 or KV-V10.

• For specific operations, refer to the instructions for the KV-V8 or KV-V10

- 13 **Power On/Standby button (⏻/⏻)**
- 14 **■ (Stop) button**
- 15 **◀◀ (Rewind)/▶▶ (Fast-forward) buttons**
- 16 **▶ (Play) button**



Before using the remote controller:

When you use the remote controller for the first time, **pull out the insulation sheet** as illustrated to the right.

- Aim the remote controller directly at the remote sensor on the color monitor. Make sure there is no obstacle in between.
- Do not expose the remote sensor to strong light (direct sunlight or artificial lighting).

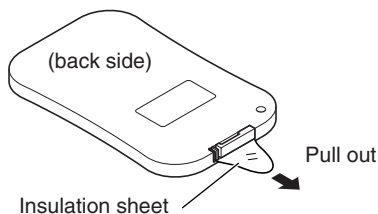

(The battery has been installed when shipped from the factory.)

Replacing the battery

When the controllable range or effectiveness of the remote controller decreases, replace the battery.

1. Remove the battery holder.

While pushing in the lock using a ball-point pen or a similar tool (①), pull out the battery holder in the direction indicated by the arrow (②).

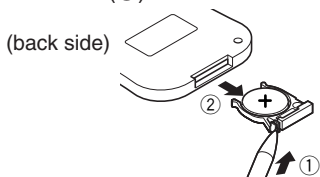

2. Replace the battery.

Slide a new battery into the holder with the + side facing upwards so that the battery is fixed in the holder.



3. Return the battery holder.

Insert the battery holder again pushing it until you hear a clicking sound.

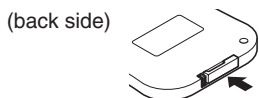

WARNING:

- Store the battery in a place which children cannot reach.
If a child accidentally swallows the battery, immediately consult a doctor.
- Do not recharge, short, disassemble or heat the battery or dispose of in a fire.
Doing any of these things may cause the battery to give off heat, crack or start a fire.
- Do not leave the battery with other metallic materials.
Doing this may cause the battery to give off heat, crack or start a fire.
- When throwing away or saving the battery, wrap in tape and insulate; otherwise, it may cause the battery to give off heat, crack or start a fire.
- Do not poke the battery with tweezers or similar tools.
Doing this may cause the battery to give off heat, crack or start a fire.

CAUTION:

DO not leave the remote controller in a place (such as dashboard) exposed to direct sunlight for a long time. Otherwise, it may be damaged.



BASIC OPERATIONS

ENGLISH

Preparation

Before operating the monitor system, make sure that all external components are correctly connected and installed.

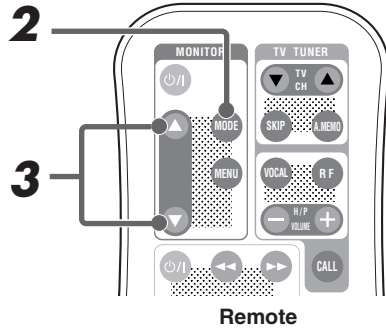
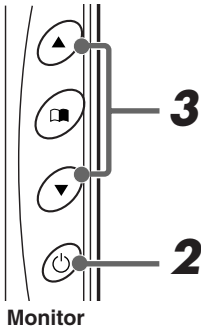

1

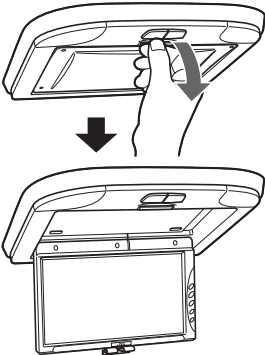

Open the liquid crystal panel.

The monitor turns on.

Note:

If the liquid crystal panel is already open, press the Power button (⏻) on the unit or the Power On/Standby button (⏻/|) on the remote control to turn on the monitor.

CAUTION:

When not in use, close the liquid crystal panel and store it into the compartment; otherwise it may obstruct the visibility through the rearview mirror.

2



Monitor



Remote

Select the input source.

Each time you press the button, the input source changes as follows:

- When KV-C10 is not connected:

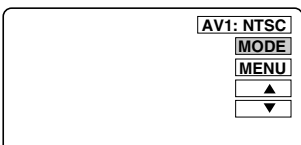
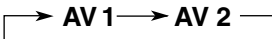

Ex. When "AV 1" is selected

- When KV-C10 is connected:



Ex. When "VIDEO 1" is selected



3

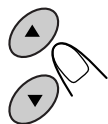

Monitor



Remote

Select the video format—NTSC or PAL, while the indication of the video format is still on the screen.

Each time you press the button, the video format alternates between NTSC (initial setting) and PAL. Select whichever matches to the incoming signals.

Note:

When not using the KV-C10: You can preset the video format separately for “AV 1” and “AV 2.”

4

Play back the external component.

To operate the external components, refer to the manuals for the connected components.

5

Select the external component and adjust the volume on the car receiver.

To check the current input source

On the monitor: Press the Power button (⏻) once.

On the remote: Press the MODE button once.

The on-screen display appears for about 5 seconds.



Monitor



Remote

To turn off the power

Close the liquid crystal panel.

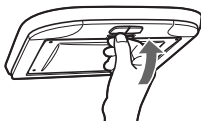

- You can also turn off the power by holding the Power button (⏻) on the unit, or by pressing the Power On/Standby button (⏻/⏻) on the remote control briefly.



Monitor



Remote



Other Basic Operations

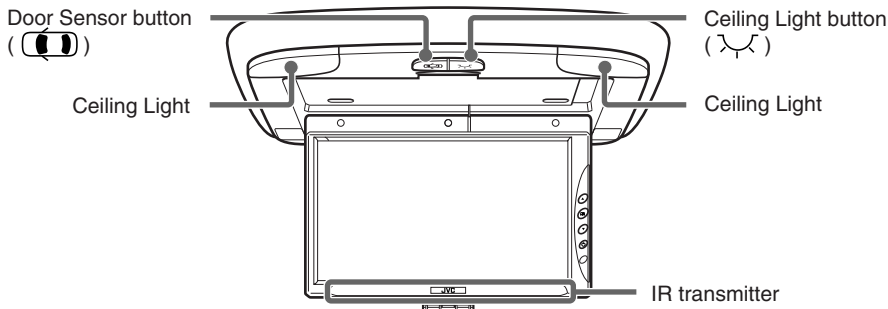

Activating the door sensor

You can activate or deactivate the door sensor by pressing the Door Sensor button (). When you activate the door sensor, the Door Sensor button glows red if the ignition switch of the car is turned to “ON” or to “ACC.”

- With the door sensor activated, the ceiling lights go on when a door is open.

Turning on or off the ceiling lights

You can turn on or off the ceiling lights on the monitor by pressing the Ceiling Light button ().

Note:

When the Door Sensor button is on, the ceiling lights go off when the door is opened then closed even if the Ceiling Light button has been turned on.

Selecting the RF signals to the receiver

When you use JVC FM modulator KS-IF200 only:

You can listen to playback sounds from the external component through the receiver even if it is equipped with no line input.

- Refer also to the instructions of KS-IF200.

When KV-C10 is connected:

Press the RF button on the remote controller.

Each time you press the button, “RF ON” and “RF OFF” alternate and the sounds you hear through the car speakers change accordingly.

RF ON : Select to listen to the sound of the external component.

RF OFF : Select to listen to the radio (through the receiver).

Using optional cordless headphones

You can use JVC’s optional cordless headphones KS-HP1K to listen to the playback sounds of the external component.

Playback sounds of the external component are transmitted through this IR transmitter to the cordless headphones.



Using the Menu

You can make your own adjustments using the Menu.

- For the adjustable items, see the next page.

Basic procedure

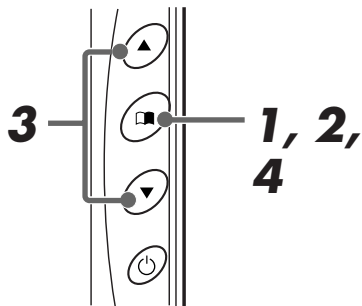

Monitor

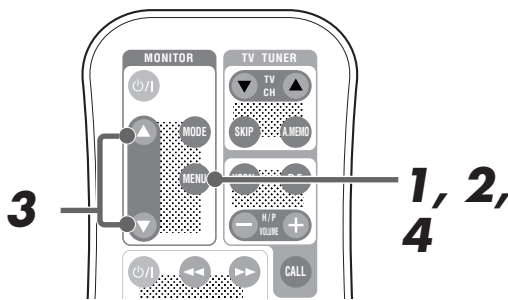

Remote

1



Monitor



Remote

Call up the Menu.

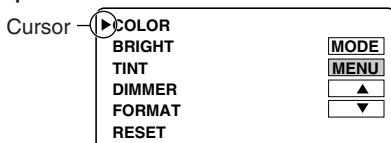

2



Monitor



Remote

Select an item you want to adjust.

Each time you press the button, the cursor moves to the next item.

3

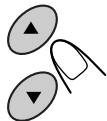

Monitor



Remote

Adjust the level of the selected item (or select an appropriate setting for the selected item).

- When "RESET" is selected in the above step, the Color, Brightness, and Tint settings are reset.

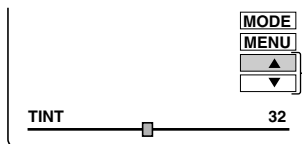

Activated button is highlighted.

Ex: When adjusting Tint

CONTINUED ON THE NEXT PAGE



4



Monitor



Remote

Exit from the Menu.

- Press the button repeatedly until the Menu is erased.

Adjustable items on the menu

Appears only for NTSC video format

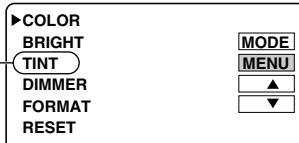

Note:

Menu goes off if no operation is done for about 5 seconds.

- COLOR** : Adjust the color of the picture—lighter or darker.
- Adjustable range: 0 to 63
 - Initial level: 32

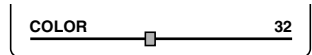

- BRIGHT** : Adjust this if the picture is too bright or too dark.
- Adjustable range: 0 to 63
 - Initial level: 32



- TINT** : Adjust this if the human skin color is unnatural.
- Adjustable range: 0 to 63
 - Initial level: 32

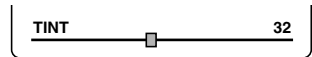

Note:

This can be shown and adjusted when the video format is NTSC.

- DIMMER** : Activate the dimmer if the inside of the car is too bright to view the picture on the screen.
- Selectable settings: ON/OFF
 - Initial setting: OFF





- FORMAT** : Select an appropriate display size.
- Selectable settings: FULL/NORMAL/ZOOM
 - Initial setting: FULL



When viewing 16:9 video signals:

- FULL:** Pictures are fully shown on the screen.
- The black bars will be shown both at the top and the bottom of the screen.
- NORMAL:** Pictures are shown at the center of the screen.
- ZOOM:** Pictures are enlarged on the screen so that no black bars will be shown on the screen. (The entire picture cannot be shown on the screen.)

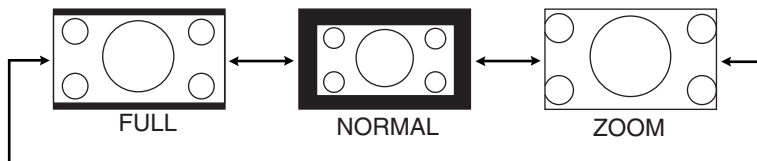

When viewing 4:3 video signals:

- FULL:** Pictures are enlarged horizontally and are fully shown on the screen.
- NORMAL:** Pictures are shown at the center of the screen.
- The black bars will be shown at the left and right sides of the screen.
- ZOOM:** Pictures are enlarged on the screen so that no black bars will be shown on the screen. (The entire picture cannot be shown on the screen.)

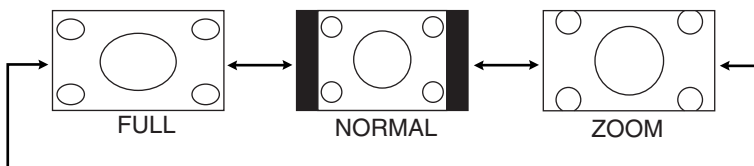

- RESET** : Reset the Color, Brightness, and Tint levels to the initial settings.

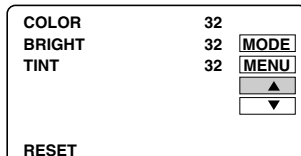



MAINTENANCE

To prevent damage to the exterior

- Do not apply pesticides, benzene, thinner or other volatile substances to the unit.
The cabinet surface primarily consists of plastic materials.
- Do not wipe with benzene, thinner or similar substances because this will result in discoloration or removal of the paint.
- When a cloth with a cleansing chemical is used, follow the caution points.
 - Do not leave the unit in contact with rubber or vinyl products for long periods of time.
 - Do not use cleansers which have polishing granules because this could damage the surface of the unit.

Clean off dirt by wiping lightly with a soft cloth

When the unit is very dirty, wipe with a well-wrung cloth dipped in a kitchen cleanser (neutral) thinned by water and then go over the same surface with a dry cloth.
(Since there is the possibility of water drops getting inside of the unit, do not directly apply cleanser to the surface.)

Caution:

If water drops or similar wet substances get inside of the monitor via the liquid crystal panel surface, it may cause a malfunction.



TROUBLESHOOTING

What appears to be trouble is not always serious. Check the following points before calling a service center.

Symptoms	Causes	Remedies
• Colored spots (red, blue and green) appear on the screen.	This is a characteristic of liquid crystal panels and is not a malfunction.	See "Note" on page 15.
• No picture appears and sound is not heard.	Correct input mode is not selected.	Select the correct input mode.
• Picture shakes vertically or colors are abnormal.	The video format (NTSC/PAL) is not correct.	Select the correct video format.
• Remote controller does not work. • Cordless headphones (not supplied) do not work.	The battery has lost its charge.	Install a new battery.
	Remote sensor is exposed to strong light.	Do not expose the remote sensor to strong light.

WIDE COLOR MONITOR

Display:

9 inch Liquid crystal panel

Number of Pixel:

336,960 pixels (480 vertical × 234 horizontal × 3)

Drive Method:

TFT (Thin Film Transistor) active matrix format

Cordless Audio:

Infrared audio transmitter (Support IR receiver stereo headphones)

L-channel: 2.3 MHz

R-channel: 2.8 MHz

Effective listening angle: 30°

Effective range: 4 m

Dimensions (W × H × D):

314 mm × 38 mm × 257 mm including Shroud

Mass: 1.2 kg including Shroud

MONITOR CONNECTION UNIT

Input

Video: RCA pin × 2 circuits
1 V(p-p), 75 Ω

Audio: RCA pin × 2 circuits
0.5 V(rms)

Tuner: 8-pin DIN connector
(only for JVC's KV-C10)

Output

Display:

13-pin DIN connector

Video: RCA pin × 1 circuit
1 V(p-p), 75 Ω

Audio: RCA pin × 1 circuit
0.5 V(rms)

Dimensions (W × H × D):

108.5 mm × 28.5 mm × 78 mm
excluding projections

Mass: 160 g

GENERAL

Power Requirement

Operating Voltage:

DC 14.4 V (11 V to 16 V allowance)

Grounding System:

Negative ground

Allowable Operating Temperature:

0°C to +40°C

Allowable Storage Temperature:

-20°C to +80°C

Ceiling light bulb: 12 V / 3 W

ACCESSORIES

Metal plate × 1

Shroud × 1

Extension cord × 1

Power cord × 1

Ceiling light cord × 1

Remote controller (with the battery) × 1

Screw (M4 × 5 mm) × 4

Screw (M4 × 12 mm) × 4

Design and specifications are subject to change without notice.

Note:

The liquid crystal panel is built with very high precision technology and has at least 99.99% effective image pixels. Be aware that on 0.01% of the panel there may be missing pixels or constantly lit pixels.



JVC

VICTOR COMPANY OF JAPAN, LIMITED



EN, GE, FR, NL

© 2003 VICTOR COMPANY OF JAPAN, LIMITED



0303MNMMDWPUN



JVC KV-MR9000

Installation/Connection Manual

Einbau/Anschlußanleitung

Manuel d'installation/raccordement

Handleiding voor installatie/aansluiting

LVT0987-004A
[E]

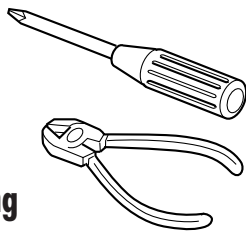

0303MNMMDWPUN
EN, GE, FR, NL

ENGLISH

DEUTSCH

FRANÇAIS

NEDERLANDS

WARNING

Installation requires some special knowledge. Do not install the monitor system yourself. Consult a dealer having special knowledge of this kind for safe and reliable installation.

DO NOT INSTALL THE MONITOR IN A LOCATION WHICH OBSTRUCTS DRIVING, VISIBILITY OR WHICH IS PROHIBITED BY APPLICABLE LAWS AND REGULATIONS.

If the monitor is installed in a location which obstructs forward visibility or operation of the air bag or other safety equipment or which interferes with operation of the vehicle, it may cause an accident.

NEVER USE BOLTS OR NUTS FROM THE VEHICLE'S SAFETY DEVICES FOR INSTALLATION.

If bolts or nuts from the steering wheel, brakes or other safety devices are used for installation of the monitor, it may cause an accident.

ATTACH THE WIRES CORRECTLY.

If the wiring is not correctly performed, it may cause a fire or an accident. In particular, be sure to run and secure the lead wire so that it does not get tangled with a screw or the moving portion of a seat rail.

USE WITH DC 12 V NEGATIVE GROUND VEHICLES.

This monitor system is only for use in a DC 12 V negative ground vehicle.

It cannot be used in large trucks or diesel vehicles which are DC 24 V vehicles.

If it is used in the wrong type of vehicle, it may cause a fire or accident.

To prevent short circuits, we recommend that you disconnect the battery's negative terminal and make all electrical connections before installing the unit. If you are not sure how to install this unit correctly, have it installed by a qualified technician.

Avoid installing the monitor connection unit in the following places

- Where it would hinder your safe driving.
- Where it would be exposed to direct sunlight or heat directly from the heater or placed in an extremely hot place.
- Where it would be subject to rain, water splashes or excessive humidity.
- Where it would be subject to dust.
- Where it would be positioned on an unstable place.
- Where it could damage the car's fittings.
- Where proper ventilation would not be maintained, such as under a floor mat.

WARNUNGEN

Die Installation erfordert entsprechende Fachkenntnisse. Installieren Sie das Monitorsystem nicht selbst. Wenden Sie sich für eine sichere und fachgerechte Installation an einen Vertragshändler.

INSTALLIEREN SIE DEN MONITOR NICHT AN EINEM ORT, AN DEM DAS FÜHREN DES FAHRZEUGS ODER DIE SICHT BEEINTRÄCHTIGT WIRD ODER DER AUFGRUND GELTENDER GESETZE UND VERORDNUNGEN UNZULÄSSIG IST.

Wenn Sie den Monitor an einem Ort installieren, an dem die Voraussicht oder der Betrieb des Airbags oder anderer Sicherheitseinrichtungen des Fahrzeugs beeinträchtigt wird oder das Führen des Fahrzeugs gestört wird, kann er die Ursache für einen Unfall sein.

VERWENDEN SIE NIEMALS SCHRAUBEN ODER MUTTERN DER SICHERHEITSEINRICHTUNGEN DES FAHRZEUGS ZUR INSTALLATION.

Wenn Schrauben oder Muttern des Lenkrads, der Bremsen oder anderer Sicherheitseinrichtungen zur Installation des Monitors verwendet werden, kann ein Unfall verursacht werden.

BRINGEN SIE DIE DRÄHTE ORDNUNGSGEMÄSS AN.

Wenn die Verkabelung nicht richtig durchgeführt wird, entsteht hierdurch möglicherweise ein Feuer oder Unfall. Achten Sie insbesondere darauf, das Kabel so zu verlegen und zu sichern, daß es sich nicht mit einer Schraube oder dem beweglichen Teil einer Sitzschiene verheddert.

VERWENDEN SIE DAS GERÄT NUR IN FAHRZEUGEN MIT 12-V-GLEICHSTROM-SYSTEM UND NEGATIVER ERDUNG.

Dieser Monitor darf nur in Fahrzeugen mit einem 12-V-Gleichstromsystem und Negativer Erdung verwendet werden.

Er darf nicht in großen Lkw oder Diesel-fahrzeugen mit 24-V-Gleichstromsystemen verwendet werden. Wenn der Monitor im falschen Fahrzeugtyp verwendet wird, kann er ein Feuer oder einen Unfall verursachen.

Um einen Kurzschluß zu vermeiden, empfiehlt es sich, den negativen Pol der Batterie abzutrennen und alle elektrischen Anschlüsse vorzunehmen, bevor der Monitor installiert wird. Wenn Sie sich nicht sicher sind, wie das Gerät installiert wird, lassen Sie es von einem qualifizierten Techniker einbauen.

Die Monitor-Anschlußeinheit nicht an den folgenden Orten installieren

- an denen die Fahrsicherheit gefährdet wäre.
- an denen es direkter Sonneneinstrahlung oder Hitzeeinwirkung durch die Heizung ausgesetzt wäre. Installieren Sie es auch nicht an einem extrem heißen Ort.
- an denen es Regen, Wasserspritzern oder übermäßiger Feuchtigkeit ausgesetzt wäre.
- an denen es Staub ausgesetzt wäre.
- die instabil sind.
- an denen die Fahrzeugarmaturen beschädigt werden könnten.
- an denen keine ordnungsgemäße Belüftung aufrechterhalten werden kann, z.B. unterhalb von Bodenmatten.

AVERTISSEMENT

L'installation nécessite certaines connaissances spéciales. N'installez pas le moniteur vous-même. Consultez un revendeur possédant les connaissances spéciales nécessaires pour une installation correcte et sûre.

N'installez pas le moniteur dans un endroit qui gêne la conduite, la visibilité ou qui est interdit par le code de la route et les règlements.

Si le moniteur était installé à un emplacement gênant la visibilité avant, ou le déploiement du sac à air, et autres dispositifs de sécurité, ou à un emplacement gênant pour la conduite du véhicule, comme près du levier des vitesses ou de la pédale du frein, cela risquerait de provoquer des accidents.

NE JAMAIS UTILISER POUR L'INSTALLATION DES BOULONS OU DES ÉCROUS PROVENANT DES DISPOSITIFS DE SÉCURITÉ DU VÉHICULE.

Si l'on utilisait pour l'utilisation du moniteur des boulons et des écrous cannibalisés du volant, des freins ou autres dispositifs de sécurité, cela risquerait de provoquer des accidents.

ATTACHER LES CORDONS CORRECTEMENT.

Si le câblage n'est pas exécuté correctement, cela risque de provoquer un incendie ou autre accident. Veiller, en particulier, à tirer et attacher les fils en sorte qu'ils ne s'accrochent pas à une vis ou ne se coincent dans les parties mobiles des rails des sièges.

USAGE SUR LES VÉHICULES DE 12 V CC AVEC NÉGATIF À LA MASSE.

Ce moniteur ne peut être utilisé que sur les véhicules de 12 V CC avec négatif à la masse. Il ne peut pas être utilisé sur les gros camions ou les véhicules diesel de 24 V CC.

S'il était utilisé sur un type de véhicule inadéquat cela risquerait de provoquer un incendie ou autres accidents.

Pour éviter les courts-circuits, nous recommandons que vous déconnectiez la borne négative de la batterie et réalisez toutes les connexions électriques avant d'installer l'appareil. Si vous n'êtes pas sûr de savoir comment installer cet appareil correctement, faites-le installer par un technicien qualifié.

Évitez d'installer l'unité de connexion du moniteur dans les endroits suivants

- Où il peut gêner la conduite de la voiture.
- Où il est exposé à la lumière directe du soleil, à la chaleur directe du chauffage ou placé dans un endroit très chaud.
- Où il est sujet à la pluie, aux éclaboussures ou à une humidité excessive.
- Où il est sujet à la poussière.
- Où il est positionné dans un endroit instable.
- Où il peut endommager les accessoires de la voiture.
- Où une ventilation correcte ne peut pas être maintenue, comme sous un tapis de sol.

WAARSCHUWING

Het installeren vereist een specifieke kennis. Installeer het monitorsysteem derhalve niet zelf. Raadpleeg de plaats van aankoop of een vakman die deze speciale kennis heeft voor het veilig en betrouwbaar installeren.

INSTALLEER DE MONITOR NIET OP EEN PLAATS WAAR DIT HET RIJDEN, OF HET UITZICHT BELEMMERT, OF WAAR DIT BIJ WET OF ANDERE REGELGEVING IS VERBODEN.

Als de monitor op een plaats is geïnstalleerd waar dit het uitzicht op de weg belemmert, dit de werking van de airbag of dit andere veiligheidsvoorzieningen hindert, of waar het besturen van het voertuig in gevaar wordt gebracht, kan dit tot een ongeval lijden.

GEBUIK NOOIT SCHROEVEN OF MOEREN VOOR DE INSTALLATIE DIE NODIG ZIJN VOOR DE VEILIGHEIDSVORZORIENINGEN VAN DE AUTO.

Als schroeven of moeren van het stuur, de rem of andere veiligheidsvoorzieningen worden gebruikt voor de installatie van de monitor, kan dit tot een ongeval lijden.

SLUIT DE BEDRADING OP DE JUISTE WIJZE AAN.

Als de bedrading verkeerd wordt aangesloten, kan dit tot brand of een ongeval lijden. Let er met name op dat de stroomvoorzieningskabel nergens achter blijft steken of in contact komt met de bewegende delen van de rails van de stoelen.

ALLEEN GEBUIKEN IN COMBINATIE MET VOERTUIGEN DIE WERKEN MET EEN NEGATIEVE AARDING VAN 12 V GELIJKSTROOM.

Dit monitorsysteem is alleen bedoeld voor voertuigen die zijn gebaseerd op een negatieve aarding van 12 V gelijkstroom.

Het systeem kan niet worden gebruikt in vrachtwagens of diesels, die met 24 V gelijkstroom werken.

Wanneer dit systeem in een verkeerd type voertuig wordt gebruikt, kan dit tot brand of een ongeval lijden.

Ter voorkoming van kortsluiting, raden we aan dat u de negatieve aansluiting van de accu losmaakt en daarna alle benodigde verbindingen tot stand brengt alvorens de eenheid te installeren. Als u niet zeker weet hoe u de eenheid moet installeren, kunt u dit beter door een erkend vakman laten doen.

Installeer het monitor-aansluitgedeelte niet op de volgende plaatsen

- waar deze een gevaar vormt voor het besturen van de auto.
- waar deze wordt blootgesteld aan direct zonlicht, een verwarming of een andere hittebron.
- waar deze wordt blootgesteld aan regen, spatwater of extreme vochtigheid.
- waar deze wordt blootgesteld aan stof.
- waar deze op een instabiele ondergrond komt te staan.
- waar deze de auto kan beschadigen.
- waar geen ventilatie is, zoals onder een vloermat.

CAUTION

Since there may be legal regulations defining the permissible installation locations for the color monitor which differ by country or by state, be sure to install the color monitor in a location complying with any such laws.

VORSICHT

Da es möglicherweise gesetzliche Vorschriften gibt, mit denen zulässige Installationsorte für den Farbmonitor geregelt werden und die von Staat zu Staat oder Bundesland zu Bundesland unterschiedlich sein können, vergewissern Sie sich, daß Sie den Farbmonitor an einem Ort installieren, der mit den gesetzlichen Vorschriften im Einklang steht.

ATTENTION

Il peut y avoir des réglementations définissant les emplacements d'installation autorisés pour un moniteur couleur et celles-ci peuvent varier d'une région à l'autre. Assurez-vous d'installer le moniteur dans un endroit conforme à ces lois.

LET OP!

Mogelijk zijn er in uw land of regio wetten of bepalingen die de installatie van de kleurenmonitor op bepaalde plaatsen in de auto verbieden. Installeer de kleurenmonitor altijd in overeenstemming met dergelijke regelgeving.

Parts list for installation and connection

The following parts are provided with this unit. After checking them, please set them correctly.

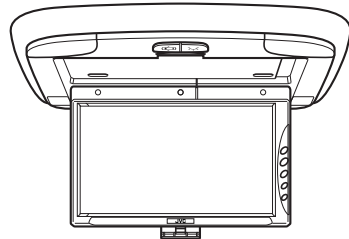

Wide color monitor (center unit and shroud)
Breitbild-Farbmonitor
(Mittlere Einheit und Abschirmung)
Moniteur couleur à écran large
(unité centrale et socle de montage au plafond)
Breedkleur-monitor
(centrale toestel en versterking)

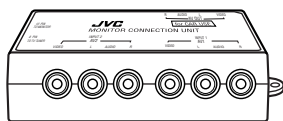

Monitor connection unit
Monitor-Anschlußeinheit
Unité de connexion du moniteur
Aansluitgedeelte van de monitor

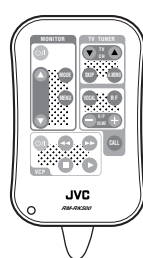

Remote controller with a battery (CR2025) installed
Fernbedienung mit einer eingebauten Batterie des Typs CR2025
Télécommande avec une pile en place (CR2025)
Afstandsbediening met een batterij (CR2025) geplaatst

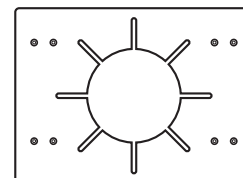

Metal plate
Metallplatte
Plaque métallique
Metalen plaat

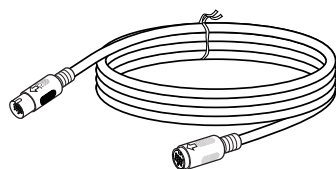

Extension cord (4 m)
Verlängerungskabel (4 m)
Cordon prolongateur (4 m)
Verlengkabel (4 m)

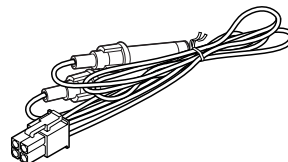

Power cord
Spannungsvorsorgungskabel
Cordon d'alimentation
Electriciteitskabel

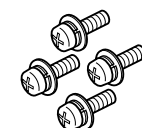

Screws (M4 x 5 mm)
Schrauben (M4 x 5 mm)
Vis (M4 x 5 mm)
Schroef (M4 x 5 mm)

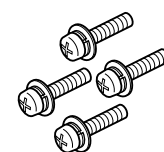

Screws (M4 x 12 mm)
Schrauben (M4 x 12 mm)
Vis (M4 x 12 mm)
Schroef (M4 x 12 mm)

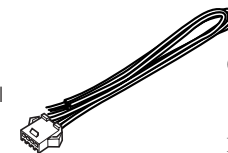

Ceiling light cord
Innenbeleuchtungskabel
Cordon de plafonnier
Plafondlicht-snoer

TROUBLESHOOTING

- The fuse blows.**
 - Are the red and black leads connected correctly?
- Power cannot be turned on.**
 - Is the yellow lead connected?
- Picture does not come on screen.**
 - Is the correct input selected?

FEHLERSUCHE

- Die Sicherung brennt durch.**
 - Sind das rote und das schwarze Kabel ordnungsgemäß angeschlossen?
- Die Stromversorgung kann nicht eingeschaltet werden.**
 - Ist das gelbe Kabel angeschlossen?
- Auf dem Bildschirm erscheint kein Bild.**
 - Wurde der richtige Eingang ausgewählt?

EN CAS DE DIFFICULTÉS

- Le fusible saute.**
 - Les fils rouge et noir sont-ils raccordés correctement?
- L'appareil ne peut pas être mise sous tension.**
 - Le fil jaune est-elle raccordée?
- Aucune image n'apparaît sur l'écran.**
 - L'entrée correcte est-elle choisie?

PROBLEMEN OPLOSSEN

- De zekering brandt door.**
 - Zijn de rode en zwarte kabels goed aangesloten?
- De stroom kan niet worden ingeschakeld.**
 - Is de gele kabel aangesloten?
- Er is geen beeld op het scherm.**
 - Is de juiste ingang gekozen?

INSTALLATION

- The following illustration shows a typical installation. However, you should make adjustments corresponding to your specific car. If you have any questions or require information regarding installation kits, consult your JVC IN-CAR ENTERTAINMENT dealer or a company supplying kits.

Einbau

- Die folgende Abbildung zeigt einen typischen Einbau. Dennoch müssen Sie entsprechend Ihrem jeweiligen Auto Anpassungen vornehmen. Bei irgendwelchen Fragen oder wenn Sie Informationen hinsichtlich des Einbausatzes brauchen, wenden Sie sich an ihren JVC-Autoradiofachhändler oder ein Unternehmen das diese Einbausätze vertreibt.

INSTALLATION

- L'illustration suivante est un exemple d'installation typique. Cependant, vous devez faire les ajustements correspondant à votre voiture particulière. Si vous avez des questions ou avez besoin d'information sur des kits d'installation, consulter votre revendeur d'autoradios JVC ou une compagnie d'approvisionnement.

INSTALLATIE

- Op de volgende afbeelding kunt u zien hoe de installatie, normaal gesproken, in zijn werk gaat. U moet echter bij de installatie rekening houden met de bijzonderheden van uw eigen auto. Neem bij vragen of voor meer bijzonderheden over inbouwpakketten contact op met uw JVC auto audiohandelaar of een dealer of een bedrijf dat inbouwpakketten levert.

Mounting the color monitor

Installation procedure varies among different cars. The following is an example. **It is recommended to have the monitor system installed by a qualified technician.**

Before mounting the monitor to the ceiling:

- Perform the required external connections first.

Monitor befestigen

Das Installationsverfahren hängt von dem jeweiligen Fahrzeugtyp ab. Das folgende ist ein Beispiel. **Es wird empfohlen, daß das Monitorsystem durch einen qualifizierten Techniker installiert wird.**

Vor der Installation des Monitors an der Decke:

- Schließen Sie die externen Anschlüsse zuerst an.

Montage du moniteur couleur

La procédure d'installation varie d'une voiture à l'autre. La procédure qui suit est un exemple. **Il est recommandé de faire installer le système de moniteur par un technicien qualifié.**

Avant de fixer le moniteur au plafond:

- Réalisez d'abord les connexions extérieures nécessaires.

Bevestigen van de kleurenmonitor

De installatiewijze verschilt afhankelijk van het type auto. Hier wordt slechts een voorbeeld gegeven. **Laat bij voorkeur het monitorsysteem door een erkend technicus installeren.**

Alvorens de monitor aan het plafond te bevestigen:

- Maak eerst de vereiste externe verbindingen.

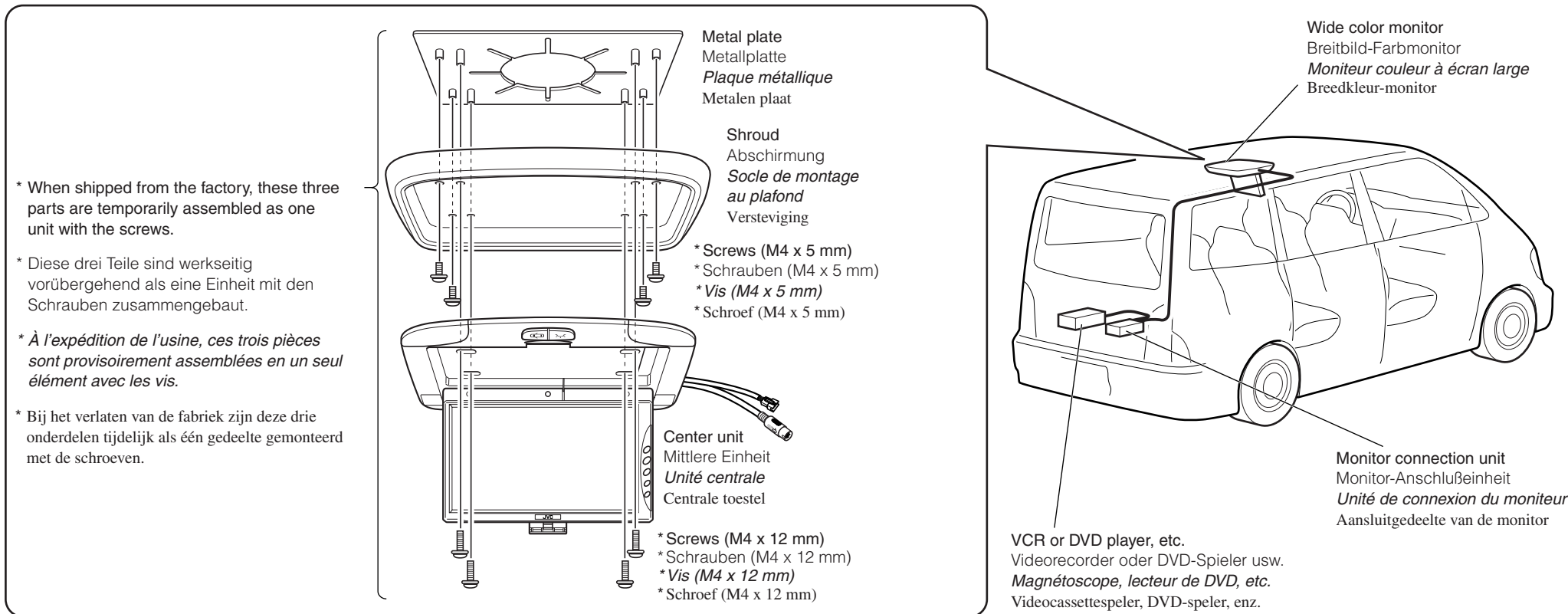

Replacing the ceiling light bulbs / Glühlampen der Innenbeleuchtung austauschen / Remplacement des ampoules du plafonnier / Vervangen van de lampjes van het plafondlicht

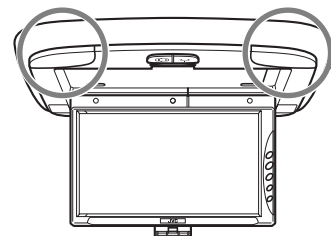

To remove the ceiling light cover, proportionally loosen the screws fixing the center unit.
Lösen Sie gleichmäßig die Schrauben, die die mittlere Einheit befestigen, um die Abdeckung der Innenbeleuchtung zu entfernen.
Pour retirer le couvercle du plafonnier desserrez proportionnellement les vis fixant l'unité centrale.
Los gelijkmatig de schroeven waarmee het centrale toestel is bevestigd voor het verwijderen van de afdekking van het plafondlicht.

1

Ceiling light cover
Abdeckung für Innenbeleuchtung
Couvercle de plafonnier
Afdekking plafondlicht

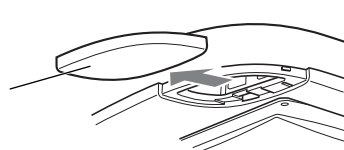

2

Ceiling light bulb
Glühlampe für Innenbeleuchtung
Ampoule de plafonnier
Lampje plafondlicht

ELECTRICAL CONNECTIONS

ELEKTRISCHE ANSCHLÜSSE

RACCORDEMENTS ELECTRIQUES

ELEKTRISCHE VERBINDINGEN

To prevent short circuits, we recommend that you disconnect the battery's negative terminal and make all electrical connections before installing the unit. If you are not sure how to install this unit correctly, have it installed by a qualified technician.

Zur Vermeidung von Kurzschlüssen empfehlen wir, daß Sie den negativen Batterieanschluß abtrennen und alle elektrischen Anschlüsse herstellen, bevor das Gerät eingebaut wird. Sind Sie sich über den richtigen Einbau des Geräts nicht sicher, lassen Sie es von einem qualifizierten Techniker einbauen.

Pour éviter tout court-circuit, nous vous recommandons de débrancher la borne négative de la batterie et d'effectuer tous les raccordements électriques avant d'installer l'appareil. Si l'on n'est pas sûr de pouvoir installer correctement cet appareil, le faire installer par un technicien qualifié.

Om kortsluiting te voorkomen adviseren wij u om de minpool van de accu los te maken en alle elektrische verbindingen tot stand te brengen voordat u het apparaat in de auto installeert. Als u niet zeker weet hoe u dit apparaat moet installeren, kunt u dit beter door een daartoe gekwalificeerde technicus laten doen.

Note:

This unit is designed to operate on **12V DC, NEGATIVE ground electrical systems**. If your vehicle does not have this system, a voltage inverter is required, which can be purchased at JVC IN-CAR ENTERTAINMENT dealers.

- Replace the fuse with one of the specified ratings. If the fuse blows frequently, consult your JVC IN-CAR ENTERTAINMENT dealer.

Hinweis:

Dieses Gerät ist für den Betrieb in **elektrischen Anlagen mit 12V Gleichstrom und (-) Erdung** ausgelegt. Verfügt Ihr Fahrzeug nicht über diese Anlage, ist ein Spannungsinverter erforderlich, der bei JVC-Autoradiofachhändler erworben werden kann.

- Die Sicherung mit einer der entsprechenden Nennleistung ersetzen. Brennt die Sicherung häufig durch, wenden Sie sich an ihren JVC-Autoradiofachhändler.

Remarque:

Cet appareil est conçu pour fonctionner sur des sources de courant continu de 12V à masse NEGATIVE. Si votre véhicule n'offre pas ce type d'alimentation, il vous faut un convertisseur de tension, que vous pouvez acheter chez un revendeur d'autoradios JVC.

- Remplacer le fusible par un de la valeur précisée. Si le fusible saute souvent, consulter votre revendeur d'autoradios JVC.

Opmerking:

Dit apparaat mag worden gebruikt bij elektrische systemen die werken op **12V gelijkstroom met negatieve aarding**. Als uw auto niet is uitgerust met een dergelijk systeem, is een spanningsomzetter vereist. Dit instrument kan worden aangeschaft bij JVC auto audiohandelaar.

- Vervang de zekering door een exemplaar met het aangegeven vermogen. Als de zekering vaak doorslaat, moet u uw JVC auto audiohandelaar raadplegen.

Monitor connection unit / Monitor-Anschlußeinheit / Unité de connexion du moniteur / Aansluitgedeelte van de monitor

Front
Vorderseite
Avant
Voor

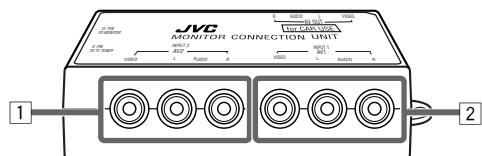

Back
Rückseite
Arrière
Achter

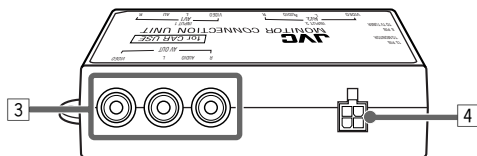

Side
Seitenansicht
Côté
Zijkant

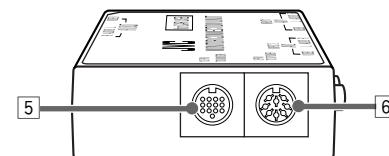

- AV 2 (INPUT 2) jacks
 - VIDEO/AUDIO L (left)/AUDIO R (right)
- AV 1 (INPUT 1) jacks
 - VIDEO/AUDIO L (left)/AUDIO R (right)
- AV OUT jacks
 - VIDEO/AUDIO L (left)/AUDIO R (right)
- Power Supply connector
- TO MONITOR (13 PIN) connector
- TO TV TUNER (8 PIN) connector

- AV 2 (INPUT 2) Anschlüsse
 - VIDEO/AUDIO L (links)/AUDIO R (rechts)
- AV 1 (INPUT 1) Anschlüsse
 - VIDEO/AUDIO L (links)/AUDIO R (rechts)
- AV OUT Anschlüsse
 - VIDEO/AUDIO L (links)/AUDIO R (rechts)
- Stromversorgungsanschluß
- TO MONITOR (13 PIN) Anschluß
- TO TV TUNER (8 PIN) Anschluß

- Prises AV 2 (INPUT 2)
 - VIDEO/AUDIO L (gauche)/AUDIO R (droit)
- Prises AV 1 (INPUT 1)
 - VIDEO/AUDIO L (gauche)/AUDIO R (droit)
- Prises AV OUT
 - VIDEO/AUDIO L (gauche)/AUDIO R (droit)
- Connecteur d'alimentation
- Connecteur TO MONITOR (13 PIN)
- Connecteur TO TV TUNER (8 PIN)

- AV 2 (INPUT 2) aansluitingen
 - VIDEO/AUDIO L (links)/AUDIO R (rechts)
- AV 1 (INPUT 1) aansluitingen
 - VIDEO/AUDIO L (links)/AUDIO R (rechts)
- AV OUT aansluitingen
 - VIDEO/AUDIO L (links)/AUDIO R (rechts)
- Aansluiting voor stroomtoevoer
- TO MONITOR (13 PIN) aansluiting
- TO TV TUNER (8 PIN) aansluiting

Typical Connections / Typische Anschlüsse / Raccordements typiques / Normale verbindingen

Before connecting: Check the wiring in the vehicle carefully. Incorrect connection may cause serious damage to this unit.
The leads of the power cord and the ceiling light cord and those of the connector from the car body may be different in color.

Vor dem Anschließen: Die Verdrahtung im Fahrzeug sorgfältig überprüfen. Falsche Anschlüsse können ernsthafte Schäden am Gerät hervorrufen.
Die Kabel von Stromversorgung, Innenbeleuchtung und der Anschluss zur Fahrzeugmasse haben möglicherweise unterschiedliche Farben.

Avant de commencer la connexion: Vérifiez attentivement le câblage du véhicule. Une connexion incorrecte peut endommager sérieusement l'appareil.
Les fils du cordon d'alimentation et du cordon du plafonnier et ceux du connecteur provenant de la voiture peuvent être de couleur différente.

Alvorens de verbindingen tot stand te brengen: Moet u de bedrading in de auto zorgvuldig. Het apparaat kan door verkeerde verbindingen ernstige schade oplopen.
De draden van het stroomtoevoer en het plafonlicht-snoer en die van de aansluitingen in de auto zijn mogelijk verschillend van kleur.

Power supply connection

1 Connect the colored leads of the power cord to the car battery, remote control and parking brake in the following sequence.

- ① Black: ground
- ② Yellow: to car battery (constant 12 V)
- ③ Red: to an accessory terminal
- ④ Blue: to remote control lead of the external component (such as KS-IF200)

2 Finally connect the wiring harness to the unit.

Stromversorgungsanschluf

1 Schließen Sie die farbigen Kabel des Spannungsversorgungskabels in der folgenden Reihenfolge an die Autobatterie, Fernbedienung und Feststellbremse an.

- ① Schwarz: an Erde
- ② Gelb: an die Autobatterie (12 V Gleichstrom)
- ③ Rot: an den Hilfsanschluß
- ④ Blau: an Fernsteuerkabel der externen Komponente (wie z. B. KS-IF200)

2 Schließen Sie zum Schluß den Kabelbaum an das Gerät an.

Connexion de l'alimentation

1 Connectez les fils de couleur du cordon d'alimentation à la batterie de la voiture, aux enceintes et à l'antenne automatique (s'il y en a une) dans l'ordre suivant.

- ① Noir: à la masse
- ② Jaune: à la batterie de la voiture (12 V constant)
- ③ Rouge: à la prise accessoire
- ④ Bleu: au fil de télécommande de l'appareil extérieur (tel que le KS-IF200)

2 Finalement, connectez le faisceau de fils à l'appareil.

Aansluiten van de stroomtoevoer

1 Sluit de gekleurde draden van de stroomtoevoer in de onderstaande volgorde aan op de accu van de auto, de afstandsbediening en de parkeerrem:

- ① Zwart: aarde
- ② Geel: naar de accu van de auto (constant 12 V)
- ③ Rood: naar het aansluitpunt van een accessoire
- ④ Blauw: naar het afstandsbedieningsdraad van het externe component (bijvoorbeeld de KS-IF200)

2 Sluit tot slot de bedrading naar de eenheid aan.

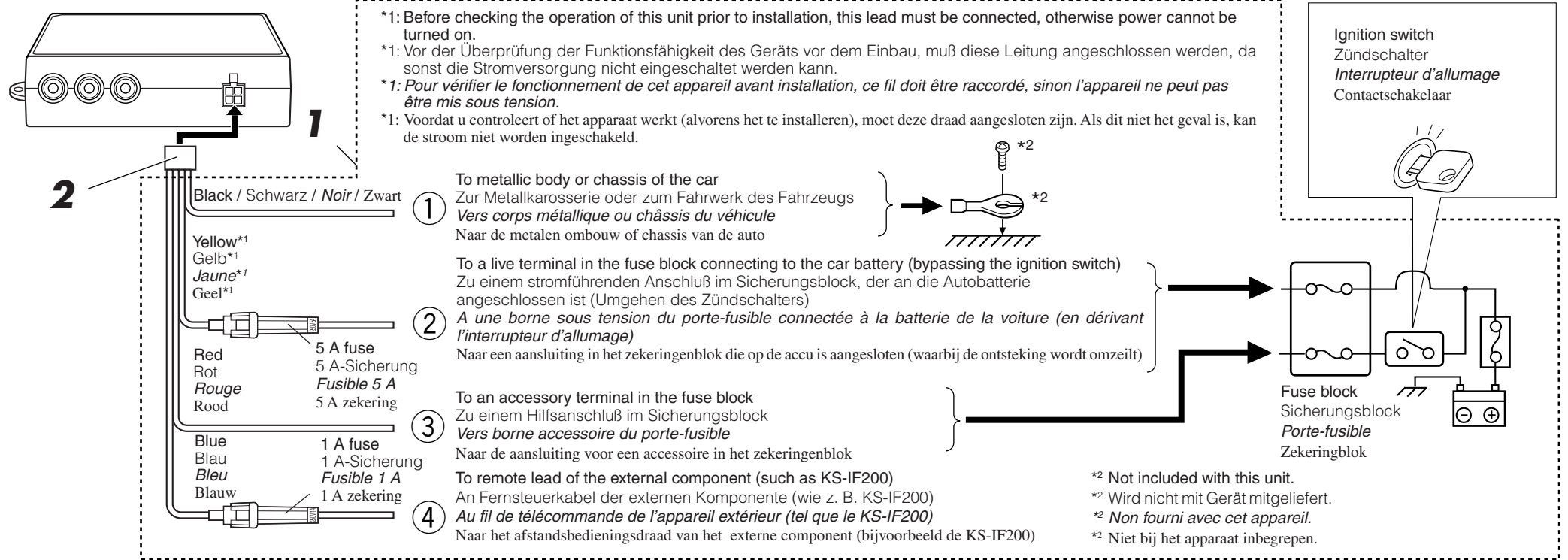

Ceiling light connection

1 Connect the colored leads of the ceiling light cord in the following sequence.

- ① Black: ground (GND)
- ② Yellow: to car battery (constant 12 V) (BATTERY B+)
- ③ Red: to an accessory terminal (ACC)
- ④ Grey: to the door sensor (DOOR SW)

Anschluss für Innenbeleuchtung

1 Schließen Sie die farbigen Leitungen des Innenbeleuchtungskabels in der folgenden Reihenfolge an:

- ① Schwarz: an Erde (GND)
- ② Gelb: an die Autobatterie (12 V Gleichstrom) (BATTERY B+)
- ③ Rot: an den Hilfsanschluß (ACC)
- ④ Grau: zum Türkontakt (DOOR SW)

Connexion de plafonnier

1 Connectez les fils de couleur du cordon du plafonnier dans l'ordre suivant.

- ① Noir: à la masse (GND)
- ② Jaune: à la batterie de la voiture (12 V constant) (BATTERY B+)
- ③ Rouge: à la prise accessoire (ACC)
- ④ Gris: au capteur de porte (DOOR SW)

Aansluiten van het plafonlicht

1 Verbind de gekleurde draden van het plafonlichtsnoer in de volgende volgorde.

- ① Zwart: aarde (GND)
- ② Geel: naar de accu van de auto (constant 12 V) (BATTERY B+)
- ③ Rood: naar het aansluitpunt van een accessoire (ACC)
- ④ Grijs: naar portiersensor (DOOR SW)

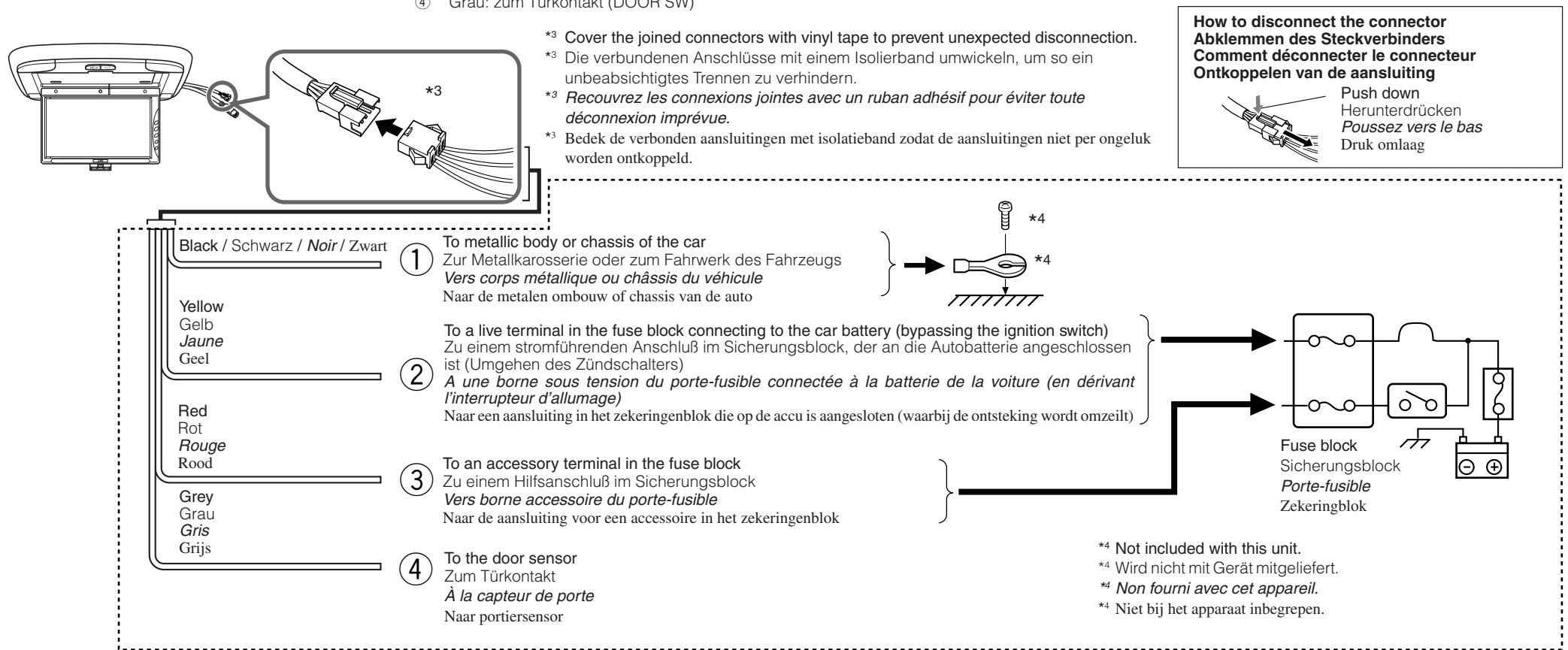

Connecting the leads / Anschließen der Leitungen / Raccordement des fils / Aansluiting van de gekleurde draden

Twist the core wires when connecting. Die Kerndrähte beim Anschließen verdrehen. *Torsader les âmes des fils en les raccordant.* Draai de kerndraden om elkaar heen wanneer u ze wilt aansluiten.

Solder the core wires to connect them securely. Die Kerndrähte anlöten, um sie fest anzuschließen. *Souder les âmes des fils pour les raccorder entre eux de façon sûre.* Soldeer de kerndraden zodat ze stevig vast zitten.

CAUTION / VORSICHT / PRECAUTION / LET OP!:

- To prevent short-circuit, cover the terminals of the UNUSED leads with insulating tape.
- Zur Vermeidung eines Kurzschlusses die Anschlußklemmen der NICHT VERWENDETEN Leitungen mit Isolierklebeband umwickeln.
- Pour éviter les court-circuits, couvrir les bornes des fils qui ne sont PAS utilisés avec de la bande isolante.
- Om kortsluiting te voorkomen, moet u de aansluitklemmen van ONGEBRUIKTE gekleurde draden met isolatieband bedekken.

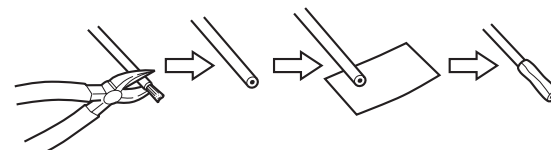
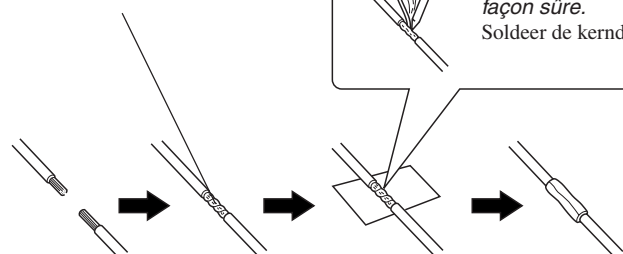

CONNECTING THE EXTERNAL COMPONENTS

Connect the monitor to TO MONITOR jack. If the monitor cord is not long enough for connection, use the extension cord supplied with the unit. This unit provides 2 input circuits and 1 output circuit. Connect one or two playback sources to AV 1 (INPUT 1) and/or AV 2 (INPUT 2) and connect reproducing components, such as a car receiver, to AV OUT.

ANSCHLIESSEN EXTERNER KOMPONENTEN

Schließen Sie Monitor an die Buchse TO MONITOR an. Wenn das Monitorkabel für den Anschluß nicht lang genug ist, verwenden Sie das Verlängerungskabel, das zum Lieferumfang des Geräts gehört. Die Monitor-Anschlußeinheit stellt zwei 2 Eingangs- und einen Ausgangskreis zur Verfügung. Schließen Sie eine oder zwei Wiedergabesignalquellen an AV 1 (INPUT 1) und/oder AV 2 (INPUT 2) und eine Reproduktionskomponente, z.B. einen Autoreceiver, an AV OUT.

CONNEXION DES APPAREILS EXTERIEURS

Connectez le moniteur couleur à la prise TO MONITOR. Si le cordon du moniteur n'est pas assez long pour la connexion, utilisez le cordon prolongateur fourni avec cet appareil. L'unité de connexion du moniteur possède 2 circuits d'entrée et un circuit de sortie. Connectez une ou deux sources de lecture à la prise AV 1 (INPUT 1) et/ou à la prise AV 2 (INPUT 2) et connectez un appareil de traitement du son tel qu'un récepteur d'autoradio à la AV OUT.

DE EXTERNE ONDERDELEN AANSLUITEN

Sluit de kleurenmonitor aan op de TO MONITOR-bus. Als de monitorkabel niet lang genoeg is om deze te kunnen aansluiten, kunt u de meegeleverde verlengkabel gebruiken. Het monitor-aansluitgedeelte heeft 2 ingangscircuits en 1 uitgangscircuit. Sluit 1 of 2 afspelbronnen aan op de AV 1 (INPUT 1)-bus en/of AV 2 (INPUT 2)-bus, en sluit een reproductiebron, zoals een autoradio-ontvanger, aan op de AV OUT.

• When not using the mobile TV tuner system KV-C10 / Bei Nichtbenutzung des mobilen TV-Tuner-Systems KV-C10 / Lorsque vous n'utilisez pas le système de tuner de télévision mobile KV-C10 / Indien u het draagbare KV-C10 TV-tunersysteem niet gebruikt

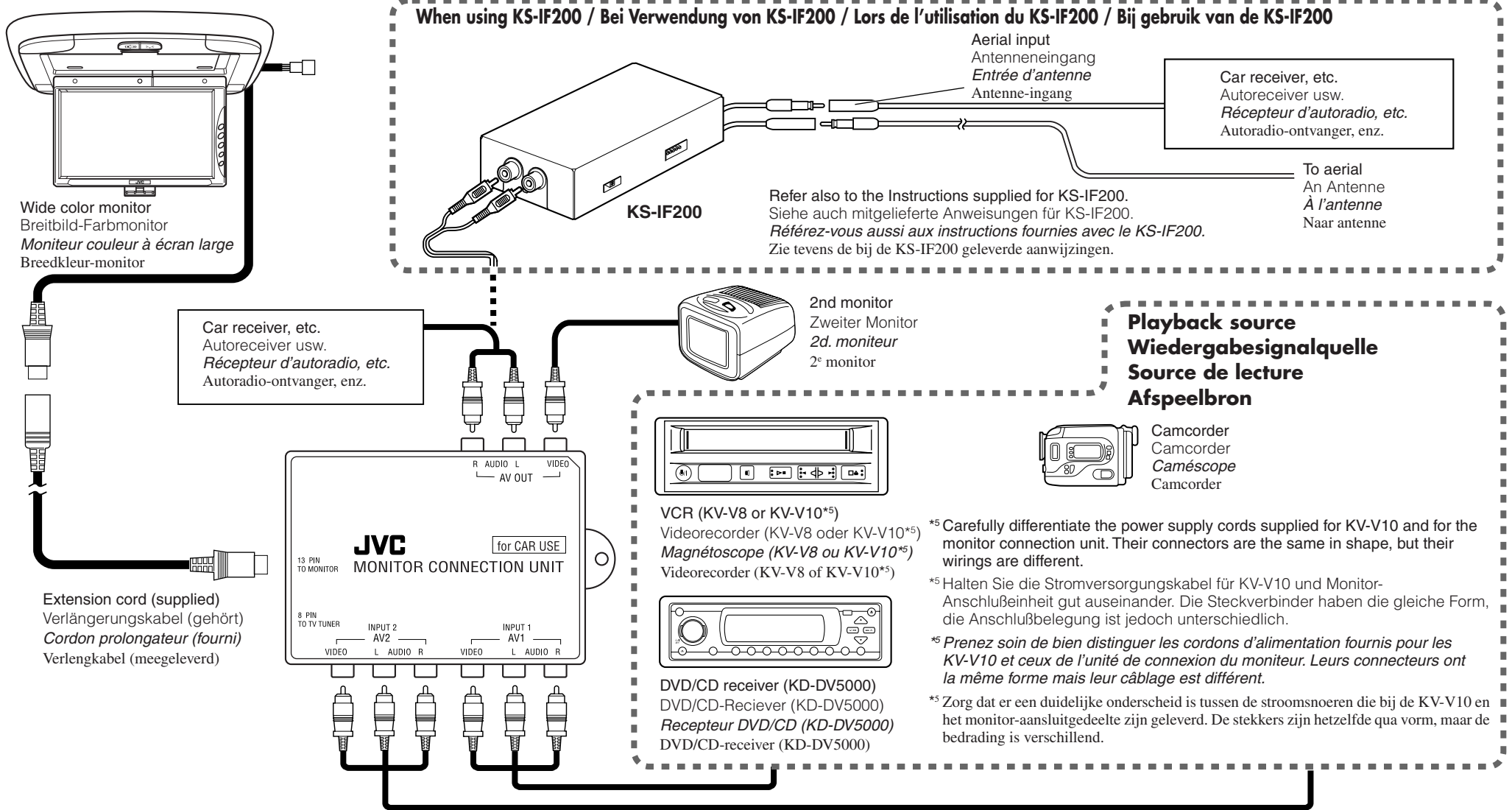

• When using the mobile TV tuner system KV-C10 / Bei Verwendung des mobilen TV-Tuner-Systems KV-C10 / Lors de l'utilisation du système de tuner de télévision mobile KV-C10 / Bij gebruik van het draagbare KV-C10 TV-tunersysteem

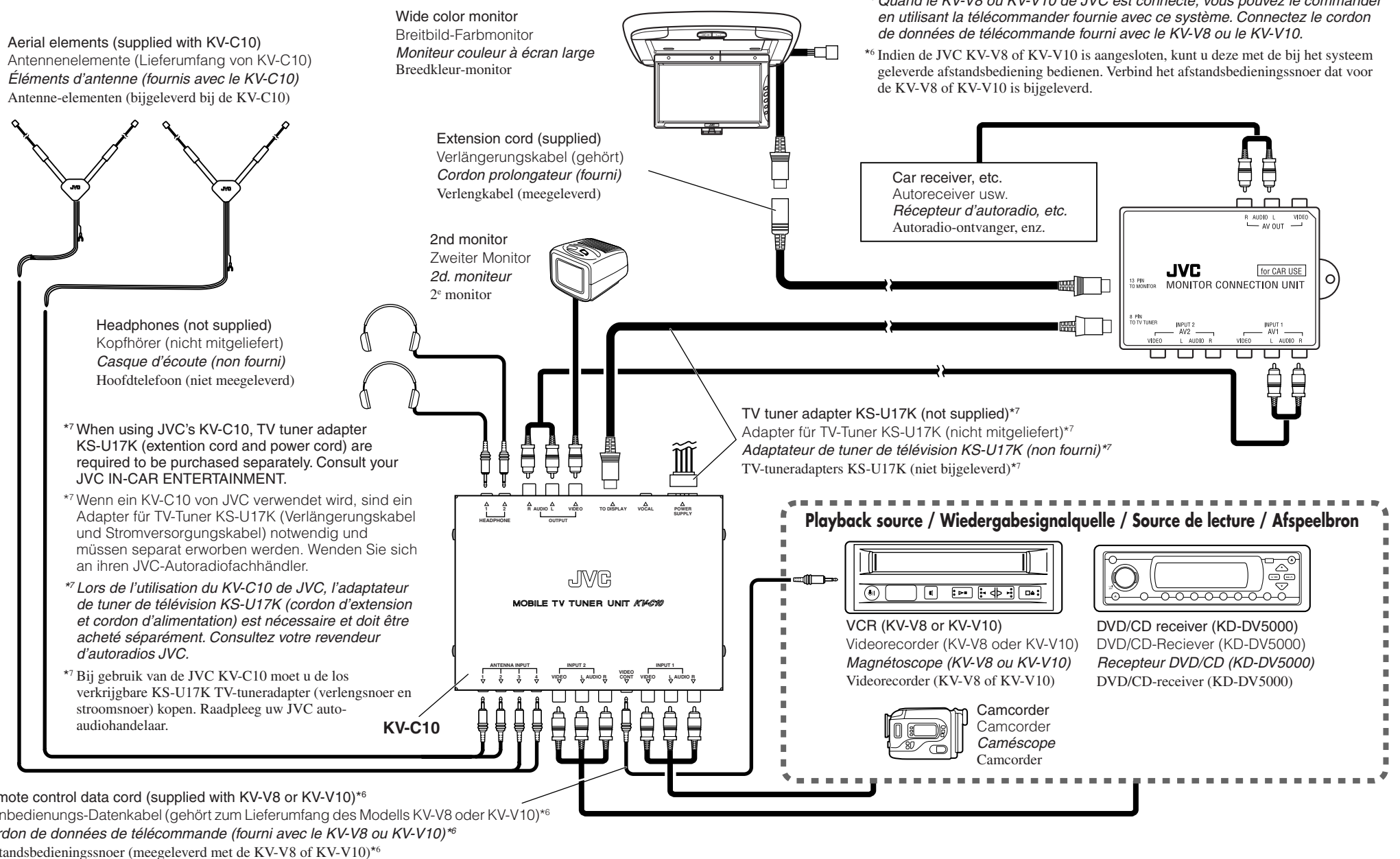

JVC



ENGLISH

9-INCH WIDE COLOR MONITOR

KV-MR9000

中文

9-英寸寬螢幕彩色監視器

KV-MR9000

ไทย

หน้าจอสีกว้าง 9 นิ้ว

KV-MR9000

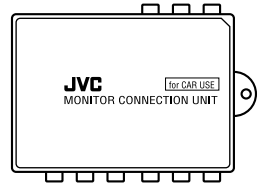
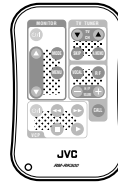
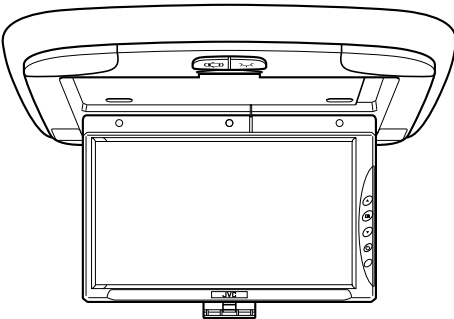

For installation and connections, refer to the separate manual.

有關安裝和連接方法，分別參閱操作手冊。

กรุณาดูคู่มือที่แยกต่างหาก ในการติดตั้งและการเชื่อมต่อ

* This system cannot receive television broadcasts and is primarily designed for use with a VCR or a DVD player. Use the separately sold mobile TV tuner unit KV-C10 for optional television broadcast reception.

* 本系統無法接收電視廣播，是為使用錄影機和 DVD 視盤機而進行的特殊設計，當要接收電視廣播時，請使用另購的 KV-C10 型便攜式電視機調諧器。

* ระบบนี้ ไม่สามารถรับการแพร่ภาพสถานีโทรทัศน์และได้รับการออกแบบเบื้องต้นเพื่อใช้กับเครื่องเล่น VCR หรือ DVD สามารถใช้กับตัวปรับ TV เตlesอนที่จำหน่ายต่างหากสำหรับการรับ KV-C10 ในการแพร่ภาพโทรทัศน์ที่เป็นอุปกรณ์เสริม

INSTRUCTIONS

使用說明書

คำแนะนำ

WARNING:

TO PREVENT FIRE OR SHOCK HAZARD, DO NOT EXPOSE THIS UNIT TO RAIN OR MOISTURE.

CAUTION:

This monitor system should be used with DC 12V only. To prevent electric shocks and fire hazards, DO NOT use any other power source.

Installation requires some special knowledge.

Do not install the monitor system yourself. Consult a dealer having special knowledge of this kind for safe and reliable installation.

WARNINGS

- DO NOT INSTALL THE MONITOR IN A LOCATION WHICH OBSTRUCTS DRIVING, VISIBILITY OR WHICH IS PROHIBITED BY APPLICABLE LAWS AND REGULATIONS.
- THERE MAY BE LEGAL REGULATIONS DEFINING THE PERMISSIBLE INSTALLATION LOCATIONS FOR THE DISPLAY UNIT WHICH DIFFER BY COUNTRY OR BY STATE. BE SURE TO INSTALL THE DISPLAY UNIT IN A CORRECT LOCATION ACCORDING TO SUCH LAWS.
- DO NOT INSTALL THE MONITOR IN A LOCATION WHICH OBSTRUCTS THE OPERATION OF AN AIR BAG.
- THE DRIVER MUST NOT OPERATE THE MONITOR SYSTEM WHILE DRIVING.
OPERATING THE MONITOR WHILE DRIVING MAY LEAD TO CARELESSNESS AND CAUSE AN ACCIDENT.
* STOP YOUR VEHICLE IN A SAFE LOCATION WHEN OPERATING THE MONITOR.
- THE DRIVER MUST NOT WATCH THE TELEVISION OR VIDEOS WHILE DRIVING.
IF THE DRIVER WATCHES THE TELEVISION OR A VIDEO WHILE DRIVING, IT MAY LEAD TO CARELESSNESS AND CAUSE AN ACCIDENT.
- WHEN LIGHTNING OCCURS, DO NOT TOUCH THE ANTENNA WIRE OR THE TELEVISION.
TOUCHING THE ANTENNA WIRE OR THE TELEVISION UNDER SUCH CONDITIONS MAY CAUSE ELECTROCUTION.
- KEEP THE MONITOR AT AN APPROPRIATE SOUND LEVEL WHILE DRIVING.
DRIVING WITH THE SOUND AT A LEVEL THAT PREVENTS YOU FROM HEARING SOUNDS OUTSIDE OF AND AROUND THE VEHICLE MAY CAUSE AN ACCIDENT.
- ASK A TRAINED TECHNICIAN TO INSTALL THE MONITOR SYSTEM.
INSTALLATION AND WIRING REQUIRE TRAINING AND EXPERIENCE.
* TO BE SAFE, ASK THE SALES OUTLET WHERE YOU PURCHASED THE MONITOR SYSTEM TO PERFORM THE INSTALLATION.
- BE SURE NOT TO LET THE MONITOR FALL OR BE STRONGLY IMPACTED SINCE THIS MAY CAUSE A MALFUNCTION OR FIRE.
- DO NOT USE THE MONITOR WITH THE ENGINE OFF.
WATCHING THE MONITOR WITH THE ENGINE OFF WILL CONSUME BATTERY POWER AND MAY PREVENT THE ENGINE FROM STARTING.
- DO NOT USE ANY CEILING LIGHT BULBS OTHER THAN SPECIFIED FOR THIS UNIT (12 V, 3 W).
FAILING TO DO SO MAY POSSIBLY CAUSE FIRE.
- WHEN NOT IN USE, CLOSE THE LIQUID CRYSTAL PANEL AND STORE IT INTO THE COMPARTMENT.

Thank you for purchasing a JVC product. Please read all instructions carefully before operation, to ensure your complete understanding and to obtain the best possible performance from the unit.

CONTENTS

PRECAUTIONS	4
CONTROLS AND FEATURES	5
Wide color monitor	5
Remote controller	6
Replacing the battery	7
<hr/>	
BASIC OPERATIONS	8
Other basic operations	10
Activating the door sensor	10
Turning on or off the ceiling lights	10
Selecting the RF signals to the receiver	10
Using optional cordless headphones	10
<hr/>	
ADJUSTMENTS	11
Using the Menu	11
Basic procedure	11
Adjustable items on the menu	12
<hr/>	
MAINTENANCE	14
<hr/>	
TROUBLESHOOTING	14
<hr/>	
SPECIFICATIONS	15



BEFORE USE

* For safety....

- Do not raise the volume level too much, as this will block outside sounds, making driving dangerous.
- Stop the car before performing any complicated operations.

* Temperature inside the car....

If you have parked the car for a long time in hot or cold weather, wait until the temperature in the car becomes normal before operating the unit.



PRECAUTIONS

ENGLISH

Cautions for handling the liquid crystal panel

Do not expose the liquid crystal display to direct sunlight.

- Storage temperature range: $-20\text{ }^{\circ}\text{C}$ to $+80\text{ }^{\circ}\text{C}$

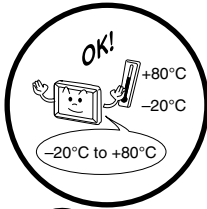

When the liquid crystal panel reaches high temperatures or low temperatures, chemical changes occur within the liquid crystal panel which may cause it to malfunction.

The red spots, blue spots and green spots on the panel surface are a normal characteristic of liquid crystal panels, and not a problem.

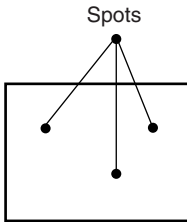

The liquid crystal panel is built with very high precision technology and has at least 99.99% effective image pixels. Be aware that on 0.01% of the panel there may be missing or constantly lit pixels.

Do not drop the liquid crystal display or strike it sharply.

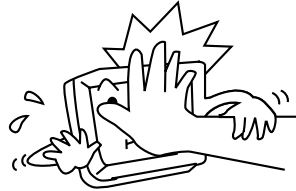

When the temperature is very cold or very hot, the image may not appear clearly or may move slowly.

The image may not be synchronized with the sound or the image quality may decline in such environments. Note that this is not a malfunction or problem.

- Usage temperature range: $0\text{ }^{\circ}\text{C}$ to $+40\text{ }^{\circ}\text{C}$



$0\text{ }^{\circ}\text{C}$ or colder

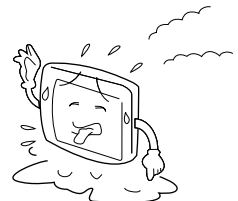

$40\text{ }^{\circ}\text{C}$ or hotter



Wide color monitor

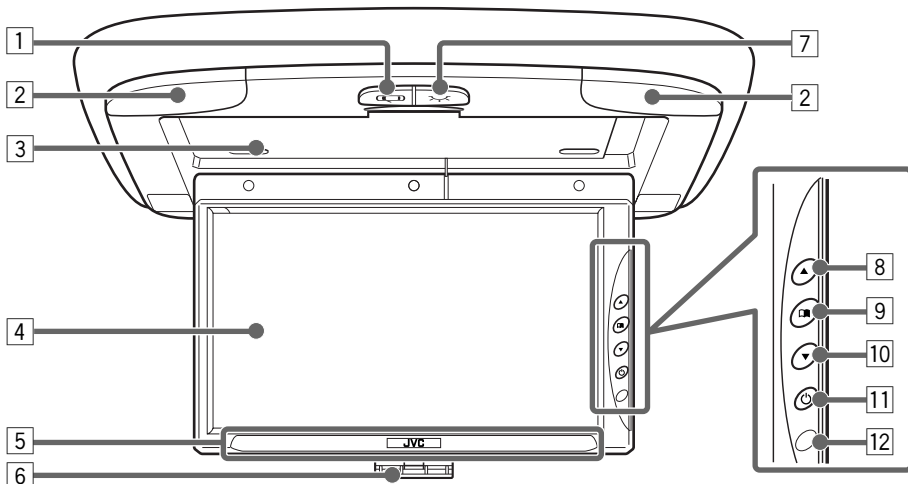

1 Door Sensor button ()

Activates or deactivates the door sensor which turns on the ceiling light when a door is open.

- When the door sensor is turned on, this button glows red.

2 Ceiling lights

3 Screen compartment

While not in use, close the screen and store it in this compartment.

4 Screen (Liquid crystal panel)

- When you open the screen, the monitor automatically turns on.
- When you close it, the monitor automatically turns off.

5 IR transmitter

- See “Specifications” for cordless headphones.

It is recommended to use JVC’s cordless headphones KS-HP1K.

6 Screen hook

- Release from the screen compartment to use the monitor.
- After using the monitor, close the screen, and hook to the screen compartment.

7 Ceiling Light button ()

Turns on or off the ceiling lights.

8 Up button ()

Increase the adjustment level of (or select an appropriate setting for) the item selected by the Menu button.

9 Menu button ()

Select an adjustment item.

10 Down button ()

Decrease the adjustment level of (or select an appropriate setting for) the item selected by the Menu button.

11 Power button ()

- Press to turn on the power.
Each time you press the button, the input mode changes when the power is on.
- Press and hold to turn off the power.

12 Remote sensor

Aim at this area when operating the monitor from the remote controller.

Note:

When you watch the screen at an angle, the picture might not be clear. This is not a malfunction. The finest picture can be seen when you watch the screen straight-on.

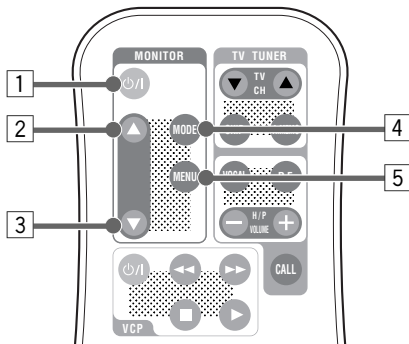
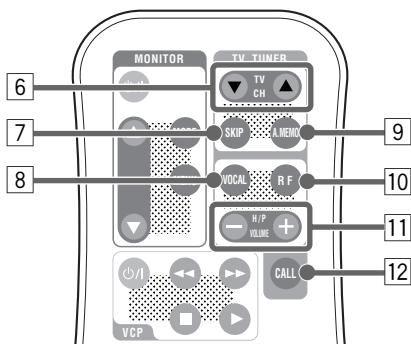
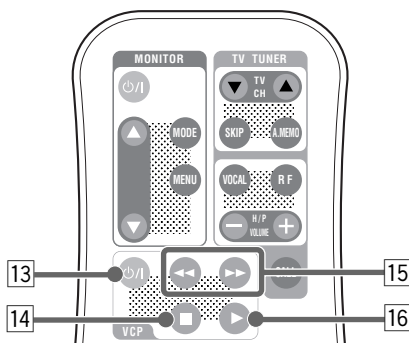
**Remote controller RM-RK500****Monitor section****TV tuner section****Video cassette player section****Monitor section**

- 1 **Power On/Standby button (⏻/⏻)**
Turn on or off the monitor system.
- 2 **Up button (▲)**
Increase the adjustment level of (or select an appropriate setting for) the item selected by the MENU button.
- 3 **Down button (▼)**
Decrease the adjustment level of (or select an appropriate setting for) the item selected by the MENU button.
- 4 **MODE button**
Each time you press the button, the input mode changes.
- 5 **MENU button**
Call up or erase the Menu screen.

TV tuner section

The following buttons can be used for operating JVC's KV-C10.

• For specific operations, refer to the instructions for the KV-C10.

- 6 **TV CH buttons (▲/▼)**
- 7 **SKIP button**
- 8 **VOCAL button**
- 9 **A.MEMO (auto memory) button**
- 10 **RF (radio frequency) button**
- 11 **H/P (headphones) VOLUME buttons (+/-)**
- 12 **CALL button**

Video cassette player (VCP) section

The following buttons can be used for operating JVC's KV-V8 or KZ-V10.

• For specific operations, refer to the instructions for the KV-V8 or KZ-V10

- 13 **Power On/Standby button (⏻/⏻)**
- 14 **■ (Stop) button**
- 15 **◀◀ (Rewind)/▶▶ (Fast-forward) buttons**
- 16 **▶ (Play) button**



Before using the remote controller:

When you use the remote controller for the first time, **pull out the insulation sheet** as illustrated to the right.

- Aim the remote controller directly at the remote sensor on the color monitor. Make sure there is no obstacle in between.
- Do not expose the remote sensor to strong light (direct sunlight or artificial lighting).

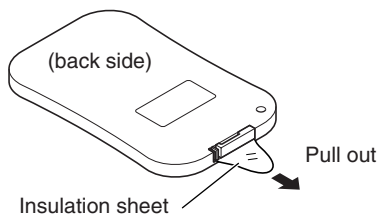

(The battery has been installed when shipped from the factory.)

Replacing the battery

When the controllable range or effectiveness of the remote controller decreases, replace the battery.

1. Remove the battery holder.

While pushing in the lock using a ball-point pen or a similar tool (①), pull out the battery holder in the direction indicated by the arrow (②).

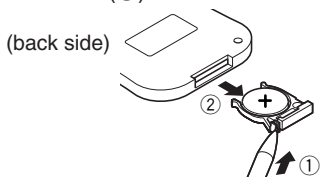

2. Replace the battery.

Slide a new battery into the holder with the + side facing upwards so that the battery is fixed in the holder.



Lithium coin battery (product number: CR2025)

3. Return the battery holder.

Insert the battery holder again pushing it until you hear a clicking sound.

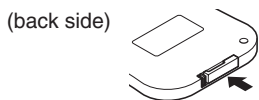

WARNING:

- Store the battery in a place which children cannot reach.
If a child accidentally swallows the battery, immediately consult a doctor.
- Do not recharge, short, disassemble or heat the battery or dispose of in a fire.
Doing any of these things may cause the battery to give off heat, crack or start a fire.
- Do not leave the battery with other metallic materials.
Doing this may cause the battery to give off heat, crack or start a fire.
- When throwing away or saving the battery, wrap in tape and insulate; otherwise, it may cause the battery to give off heat, crack or start a fire.
- Do not poke the battery with tweezers or similar tools.
Doing this may cause the battery to give off heat, crack or start a fire.

CAUTION:

DO not leave the remote controller in a place (such as dashboard) exposed to direct sunlight for a long time. Otherwise, it may be damaged.



BASIC OPERATIONS

ENGLISH

Preparation

Before operating the monitor system, make sure that all external components are correctly connected and installed.

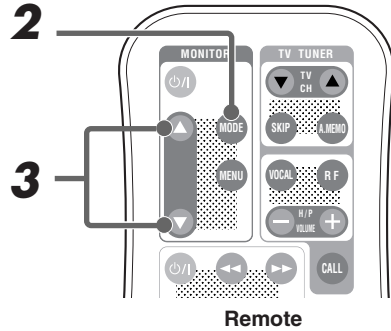
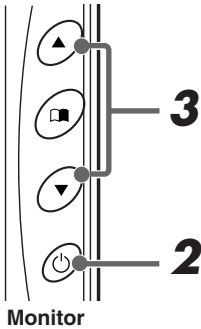

1

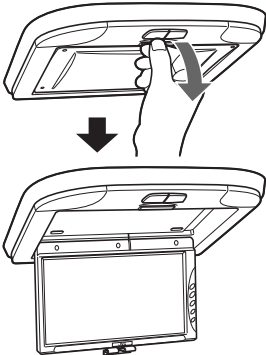

Open the liquid crystal panel.

The monitor turns on.

Note:

If the liquid crystal panel is already open, press the Power button (⏻) on the unit or the Power On/Standby button (⏻/|) on the remote control to turn on the monitor.

CAUTION:

When not in use, close the liquid crystal panel and store it into the compartment; otherwise it may obstruct the visibility through the rearview mirror.

2



Monitor



Remote

Select the input source.

Each time you press the button, the input source changes as follows:

- When KV-C10 is not connected:

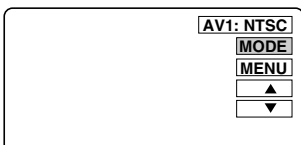
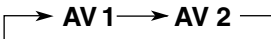

Ex. When "AV 1" is selected

- When KV-C10 is connected:



Ex. When "VIDEO 1" is selected



3

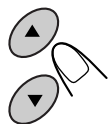

Monitor



Remote

Select the video format—NTSC or PAL, while the indication of the video format is still on the screen.

Each time you press the button, the video format alternates between NTSC (initial setting) and PAL. Select whichever matches to the incoming signals.

Note:

When not using the KV-C10: You can preset the video format separately for “AV 1” and “AV 2.”

4

Play back the external component.

To operate the external components, refer to the manuals for the connected components.

5

Select the external component and adjust the volume on the car receiver.

To check the current input source

On the monitor: Press the Power button (⏻) once.

On the remote: Press the MODE button once.

The on-screen display appears for about 5 seconds.



Monitor



Remote

To turn off the power

Close the liquid crystal panel.

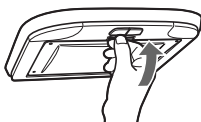

- You can also turn off the power by holding the Power button (⏻) on the unit, or by pressing the Power On/Standby button (⏻/⏻) on the remote control briefly.



Monitor



Remote



Other Basic Operations

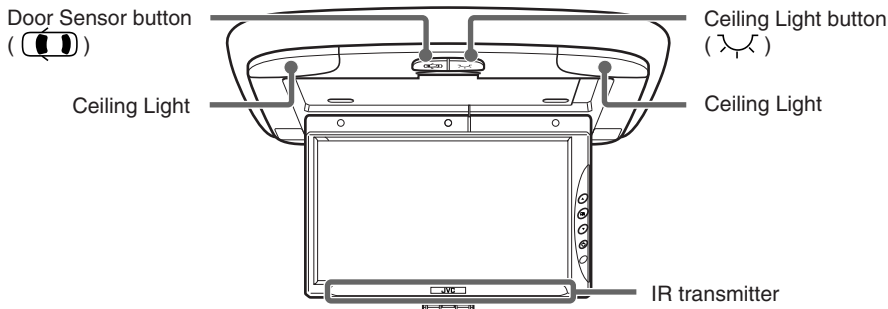

Activating the door sensor

You can activate or deactivate the door sensor by pressing the Door Sensor button (). When you activate the door sensor, the Door Sensor button glows red if the ignition switch of the car is turned to “ON” or to “ACC.”

- With the door sensor activated, the ceiling lights go on when a door is open.

Turning on or off the ceiling lights

You can turn on or off the ceiling lights on the monitor by pressing the Ceiling Light button ().

Note:

When the Door Sensor button is on, the ceiling lights go off when the door is opened then closed even if the Ceiling Light button has been turned on.

Selecting the RF signals to the receiver

When you use JVC FM modulator KS-IF200 only:

You can listen to playback sounds from the external component through the receiver even if it is equipped with no line input.

- Refer also to the instructions of KS-IF200.

When KV-C10 is connected:

Press the RF button on the remote controller.

Each time you press the button, “RF ON” and “RF OFF” alternate and the sounds you hear through the car speakers change accordingly.

RF ON : Select to listen to the sound of the external component.

RF OFF : Select to listen to the radio (through the receiver).

Using optional cordless headphones

You can use JVC’s optional cordless headphones KS-HP1K to listen to the playback sounds of the external component.

Playback sounds of the external component are transmitted through this IR transmitter to the cordless headphones.



Using the Menu

You can make your own adjustments using the Menu.

- For the adjustable items, see the next page.

Basic procedure

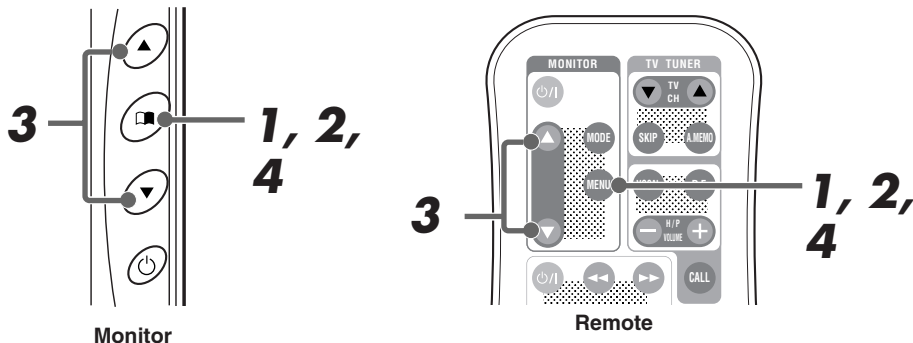

1



Monitor



Remote

Call up the Menu.

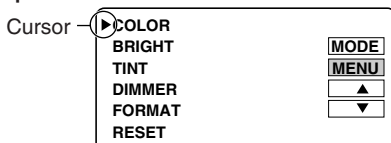

2



Monitor



Remote

Select an item you want to adjust.

Each time you press the button, the cursor moves to the next item.

3

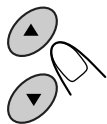

Monitor



Remote

Adjust the level of the selected item (or select an appropriate setting for the selected item).

- When "RESET" is selected in the above step, the Color, Brightness, and Tint settings are reset.

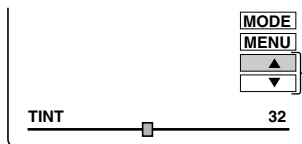

Activated button is highlighted.

Ex: When adjusting Tint

CONTINUED ON THE NEXT PAGE



4



Monitor



Remote

Exit from the Menu.

- Press the button repeatedly until the Menu is erased.

Adjustable items on the menu

Appears only for NTSC video format

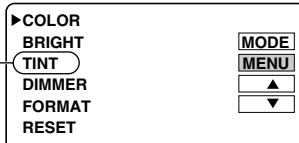

Note:

Menu goes off if no operation is done for about 5 seconds.

COLOR : Adjust the color of the picture—lighter or darker.
 • Adjustable range: 0 to 63
 • Initial level: 32

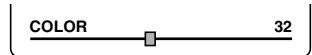

BRIGHT : Adjust this if the picture is too bright or too dark.
 • Adjustable range: 0 to 63
 • Initial level: 32

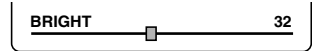

TINT : Adjust this if the human skin color is unnatural.
 • Adjustable range: 0 to 63
 • Initial level: 32

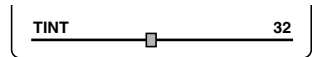

Note:

This can be shown and adjusted when the video format is NTSC.

DIMMER : Activate the dimmer if the inside of the car is too bright to view the picture on the screen.
 • Selectable settings: ON/OFF
 • Initial setting: OFF





- FORMAT** : Select an appropriate display size.
- Selectable settings: FULL/NORMAL/ZOOM
 - Initial setting: FULL



When viewing 16:9 video signals:

- FULL:** Pictures are fully shown on the screen.
- The black bars will be shown both at the top and the bottom of the screen.
- NORMAL:** Pictures are shown at the center of the screen.
- ZOOM:** Pictures are enlarged on the screen so that no black bars will be shown on the screen. (The entire picture cannot be shown on the screen.)

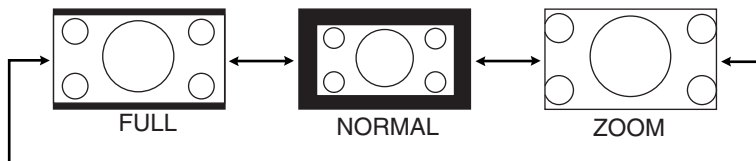

When viewing 4:3 video signals:

- FULL:** Pictures are enlarged horizontally and are fully shown on the screen.
- NORMAL:** Pictures are shown at the center of the screen.
- The black bars will be shown at the left and right sides of the screen.
- ZOOM:** Pictures are enlarged on the screen so that no black bars will be shown on the screen. (The entire picture cannot be shown on the screen.)

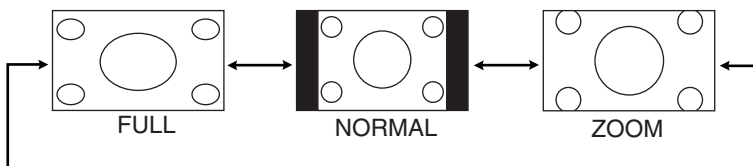

- RESET** : Reset the Color, Brightness, and Tint levels to the initial settings.

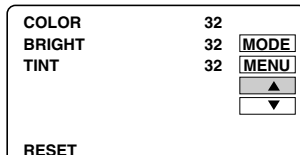



MAINTENANCE

To prevent damage to the exterior

- Do not apply pesticides, benzene, thinner or other volatile substances to the unit. The cabinet surface primarily consists of plastic materials.
- Do not wipe with benzene, thinner or similar substances because this will result in discoloration or removal of the paint.
- When a cloth with a cleansing chemical is used, follow the caution points.
 - Do not leave the unit in contact with rubber or vinyl products for long periods of time.
 - Do not use cleansers which have polishing granules because this could damage the surface of the unit.

Clean off dirt by wiping lightly with a soft cloth

When the unit is very dirty, wipe with a well-wrung cloth dipped in a kitchen cleanser (neutral) thinned by water and then go over the same surface with a dry cloth. (Since there is the possibility of water drops getting inside of the unit, do not directly apply cleanser to the surface.)

Caution:

If water drops or similar wet substances get inside of the monitor via the liquid crystal panel surface, it may cause a malfunction.



TROUBLESHOOTING

What appears to be trouble is not always serious. Check the following points before calling a service center.

Symptoms	Causes	Remedies
• Colored spots (red, blue and green) appear on the screen.	This is a characteristic of liquid crystal panels and is not a malfunction.	See "Note" on page 15.
• No picture appears and sound is not heard.	Correct input mode is not selected.	Select the correct input mode.
• Picture shakes vertically or colors are abnormal.	The video format (NTSC/PAL) is not correct.	Select the correct video format.
• Remote controller does not work. • Cordless headphones (not supplied) do not work.	The battery has lost its charge.	Install a new battery.
	Remote sensor is exposed to strong light.	Do not expose the remote sensor to strong light.

SPECIFICATIONS

WIDE COLOR MONITOR

Display:

9 inch Liquid crystal panel

Number of Pixel:

336,960 pixels (480 vertical × 234 horizontal × 3)

Drive Method:

TFT (Thin Film Transistor) active matrix format

Cordless Audio:

Infrared audio transmitter (Support IR receiver stereo headphones)

L-channel: 2.3 MHz

R-channel: 2.8 MHz

Effective listening angle: 30°

Effective range: 4 m

Dimensions (W × H × D):

314 mm × 38 mm × 257 mm including Shroud

Mass: 1.2 kg including Shroud

MONITOR CONNECTION UNIT

Input

Video: RCA pin × 2 circuits
1 V(p-p), 75 Ω

Audio: RCA pin × 2 circuits
0.5 V(rms)

Tuner: 8-pin DIN connector
(only for JVC's KV-C10)

Output

Display:

13-pin DIN connector

Video: RCA pin × 1 circuit
1 V(p-p), 75 Ω

Audio: RCA pin × 1 circuit
0.5 V(rms)

Dimensions (W × H × D):

108.5 mm × 28.5 mm × 78 mm
excluding projections

Mass: 160 g

GENERAL

Power Requirement

Operating Voltage:

DC 14.4 V (11 V to 16 V allowance)

Grounding System:

Negative ground

Allowable Operating Temperature:

0°C to +40°C

Allowable Storage Temperature:

-20°C to +80°C

Ceiling light bulb: 12 V / 3 W

ACCESSORIES

Metal plate × 1

Shroud × 1

Extension cord × 1

Power cord × 1

Ceiling light cord × 1

Remote controller (with the battery) × 1

Screw (M4 × 5 mm) × 4

Screw (M4 × 12 mm) × 4

Design and specifications are subject to change without notice.

Note:

The liquid crystal panel is built with very high precision technology and has at least 99.99% effective image pixels. Be aware that on 0.01% of the panel there may be missing pixels or constantly lit pixels.



KV-MR9000

Installation/Connection Manual

安裝/連接手冊

การติดตั้ง/คู่มือการติดตั้ง

كتيب تعليمات التثبيت/التوصيل

LVT0988-003A

[U]

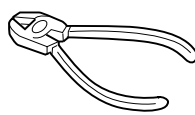
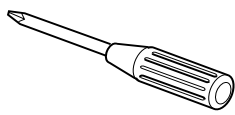

0303MNMMDWPUN
EN, CH, TH, AR

ENGLISH

中文

ไทย

عربي

WARNING

Installation requires some special knowledge. Do not install the monitor system yourself. Consult a dealer having special knowledge of this kind for safe and reliable installation.

DO NOT INSTALL THE MONITOR IN A LOCATION WHICH OBSTRUCTS DRIVING, VISIBILITY OR WHICH IS PROHIBITED BY APPLICABLE LAWS AND REGULATIONS.

If the monitor is installed in a location which obstructs forward visibility or operation of the air bag or other safety equipment or which interferes with operation of the vehicle, it may cause an accident.

NEVER USE BOLTS OR NUTS FROM THE VEHICLE'S SAFETY DEVICES FOR INSTALLATION.

If bolts or nuts from the steering wheel, brakes or other safety devices are used for installation of the monitor, it may cause an accident.

ATTACH THE WIRES CORRECTLY.

If the wiring is not correctly performed, it may cause a fire or an accident. In particular, be sure to run and secure the lead wire so that it does not get tangled with a screw or the moving portion of a seat rail.

USE WITH DC 12 V NEGATIVE GROUND VEHICLES.

This monitor system is only for use in a DC 12 V negative ground vehicle.

It cannot be used in large trucks or diesel vehicles which are DC 24 V vehicles.

If it is used in the wrong type of vehicle, it may cause a fire or accident.

To prevent short circuits, we recommend that you disconnect the battery's negative terminal and make all electrical connections before installing the unit. If you are not sure how to install this unit correctly, have it installed by a qualified technician.

Avoid installing the connection unit in the following places

- Where it would hinder your safe driving.
- Where it would be exposed to direct sunlight or heat directly from the heater or placed in an extremely hot place.
- Where it would be subject to rain, water splashes or excessive humidity.
- Where it would be subject to dust.
- Where it would be positioned on an unstable place.
- Where it could damage the car's fittings.
- Where proper ventilation would not be maintained, such as under a floor mat.

CAUTION

Since there may be legal regulations defining the permissible installation locations for the color monitor which differ by country or by state, be sure to install the color monitor in a location complying with any such laws.

警告

必須要有安裝方面特殊的知識方可進行安裝工作。請勿自行安裝監視器系統。為安全起見和可靠的安裝，請洽詢有專門知識的經銷商。

請勿將監視器安裝在妨礙駕駛，影響視線或違反交通法律和規則之處。

若將監視器裝在諸如影響前方視線，影響氣袋和其它安全裝置的操作以及妨礙車輛操縱之處時，可能會導致事故的發生。

切勿使用車輛安全裝置上的螺栓和螺母來進行安裝。

若使用輪胎轉向器，制動器或其它安全裝置上的螺栓和螺母來安裝監視器時，可能會導致事故的發生。

正確連接導線。

若沒有正確導線，可能會導致火災或意外。特別一定要注意伸展和保護引線，使其與螺絲釘或座位把手的移動部位不發生纏結。

請使用帶直流 12 V 負極接地的車輛。

此監視器系統僅限於直流 12 V 負極接地的車輛。

此監視器系統不能用直流 24 V 的負極接地的大型卡車或柴油機。

若將其用錯車型，可能導致火災或事故的發生。

為了防止短路，建議您拔掉電池的負極端子並在安裝本機之前做好所有電線的連接。若您不能確保正確安裝本機，請求助合格的技術人員進行連接。

請勿在下列地點安裝監視器連接機。

- 妨礙安全駕駛之處。
- 暴露於陽光直射或散熱源直接散熱處以及高溫處。
- 易受雨淋，濺水或過度潮濕之處。
- 易落塵埃之處。
- 不牢固之處。
- 損傷車輛零件之處。
- 通風不良之處。如地毯下面。

小心

各個國家或洲有其法律規定允許安裝彩色監視器的地點，因此務必安裝彩色監視器於符合法律的地點。

คำเตือน

ผู้ทำการติดตั้งจำเป็นต้องมีความรู้ความชำนาญ อย่าติดตั้งชุดจอภาพด้วยตัวท่านเอง โปรดปรึกษากับตัวแทนจำหน่ายที่มีความรู้ในด้านนี้ ทั้งนี้เพื่อการติดตั้งที่ปลอดภัยและเชื่อถือได้

ห้ามติดตั้งจอภาพในตำแหน่งที่อาจเป็นอุปสรรคในการขับขี่และบดบังทัศนวิสัยในการมองเห็น หรือในลักษณะที่ขัดต่อกฎหมายและกฎระเบียบที่บังคับ

หากติดตั้งจอภาพในตำแหน่งที่บดบังทัศนวิสัยในการมองเห็นที่ภาพข้างหน้า หรือขัดขวางการทำงานของถุงลมนิรภัย หรืออุปกรณ์นิรภัยอื่นๆ หรือที่ขัดขวางการทำงานของรถยนต์ อาจก่อให้เกิดอุบัติเหตุได้

ห้ามนำสลักเกลียวหรือตัวน็อตจากอุปกรณ์นิรภัยของรถยนต์มาใช้ในการติดตั้ง

หากมีการนำสลักเกลียวหรือตัวน็อตจากพวงมาลัยเบรกหรืออุปกรณ์นิรภัยอื่นๆ มาใช้ในการติดตั้งจอภาพ อาจก่อให้เกิดอุบัติเหตุได้

อย่าสายไฟให้ถูกต้อง

หากสายไฟทำงานไม่ถูกต้อง อาจทำให้เกิดไฟไหม้หรืออุบัติเหตุได้ ควรตรวจสอบให้แน่ใจว่าได้เดินและต่อสายไฟอย่างแน่นหนาเพื่อที่สายไฟจะไม่พันกันน็อต หรือวางที่นั่นที่เลื่อนไปมาได้

ใช้กับรถที่ต่อสายดินขั้วลบกระแสตรงขนาด 12 V

ชุดจอภาพนี้ใช้ได้กับรถที่ต่อสายดินขั้วลบกระแสตรงขนาด 12 V เท่านั้น

ไม่สามารถใช้ไดกับรถบรรทุกขนาดใหญ่หรือรถยนต์สี่ล้อที่ใช้ไฟฟ้กระแสตรงขนาด 24 V

หากนำไปใช้กับรถชนิดประเภท อาจก่อให้เกิดไฟไหม้หรืออุบัติเหตุได้

เพื่อป้องกันไฟฟ้ลัดวงจร ขอแนะนำให้ออดขั้วสายไฟของแบตเตอรี่ออกก่อน และทำการเชื่อมต่อไฟฟ้ทั้งหมดก่อนติดตั้งชุดจอภาพ หากไม่แน่ใจวิธีการติดตั้งที่ถูกต้องโปรดปรึกษาผู้จำหน่ายผู้ติดตั้งให้

หลีกเลี่ยงการติดตั้งชุดจอภาพในตำแหน่งดังต่อไปนี้

- ตำแหน่งที่อาจเป็นอุปสรรคต่อการขับขี่ที่ปลอดภัย
- ตำแหน่งที่รับแสงอาทิตย์โดยตรงหรือได้รับความร้อนจากเครื่องทำความร้อน หรือในตำแหน่งที่ร้อนจัด
- ตำแหน่งที่อาจถูกฝน น้ำสาดหรือมีความชื้นสูง
- ตำแหน่งที่อาจสัมผัสฝุ่นละออง
- ตำแหน่งที่ตั้งอยู่ในจุดที่ไม่มั่นคง
- ตำแหน่งที่อาจสร้างความเสียหายให้กับอุปกรณ์รถยนต์
- ตำแหน่งที่การระบายอากาศไม่สามารรถเข้าถึงได้
- เช่นใต้พรมปูพื้นรถ

ข้อควรระวัง

เนื่องจากอาจมีกฎระเบียบด้านกฎหมายซึ่งกำหนดตำแหน่งการติดตั้งที่อนุญาตสำหรับจอภาพสี ซึ่งอาจแตกต่างกันไปในแต่ละประเทศหรือรัฐ เพราะฉะนั้น โปรดแน่ใจว่าได้ติดตั้งจอภาพสีในตำแหน่งที่สอดคล้องกับกฎหมายที่กำหนดไว้

تنبيه

يتطلب التركيب بعض المعلومات الخصوصية. لا تركب جهاز المراقبة بنفسك. يرجى استشارة العميل الذي عنده معرفة خصوصية بهذا نوع من اجل التركيب الامين والموثوق به.

لا تركب المراقب في مكان يعرقل قيادة السيارة او الرؤية او في مكان ممنوع بموجب القوانين والانظمة.

اذا تم تركيب المراقب في مكان يعرقل الرؤية الامامية او تشغيل كيس الهواء او معدات الامان الاخرى او في مكان يتداخل مع تشغيل السيارة، فانه يمكن ان يسبب ذلك حصول حادث.

لا تستعمل مطلقا براغي او صواميل من اجهزة امان السيارة لتركيب المراقب.

اذا تم استعمال براغي او صواميل من عجلة القيادة او الكوابح او اجهزة الامان الاخرى لتركيب المراقب، فانه يمكن ان يسبب ذلك حصول حادث.

اوصل الاسلاك بصورة صحيحة.

اذا تم توصيل الاسلاك بصورة غير صحيحة، فانه يمكن ان يسبب ذلك حصول حريق او حادث. بصورة خاصة، تأكد من تمديد وتثبيت الاسلاك بحيث لا تتعرجل او تتشابك مع البراغي او الجزء المتحرك من عجلة المقعد.

استعمل المراقب داخل سيارات ذات تاريض ارضي سالب وتيار مباشر ١٢ فولت.

جهاز المراقب هذا مخصص فقط للاستعمال داخل سيارات ذات تاريض ارضي سالب وتيار مباشر ١٢ فولت.

لا يمكن استعمال هذا المراقب داخل سيارات الشحن الكبيرة او سيارات الديزل ذات تيار مباشر ٢٤ فولت.

اذا تم استعمال هذا المراقب داخل سيارات غير مخصصة له، فانه يمكن ان يسبب ذلك حريق او حصول حادث.

لمنع حدوث تقصير في الدوائر الكهربائية،

نوصي بفصل طرف البطارية السالب ثم عمل التوصيلات الكهربائية قبل تركيب الجهاز. في حالة عدم معرفتك بكيفية تركيب الجهاز بشكل صحيح، يرجى ترك عملية تركيب الجهاز لشخص مختص ومؤهل لتركيب مثل هذه الاجهزة.

تجنب تركيب وحدة توصيل المراقب في الاماكن التالية

- في الاماكن التي يمكن ان تعرقل قيادة السيارة بامان.
- في الاماكن التي يمكن ان يتعرض بها المراقب التي اشعة الشمس المباشرة او الحرارة المباشرة من السخان او وضع المراقب في مكان حار جدا.
- في الاماكن المعرضة للمطر او رشق الماء او الرطوبة العالية.
- في الاماكن المعرضة للغبار.
- في الاماكن التي يمكن ان يكون وضع المراقب غير ثابت.
- في الاماكن التي يمكن ان تسبب ضرر لتجهيزات السيارة.
- في الاماكن ذات التهوية غير الجيدة، مثل تحت فرش الارضية.

تنبيه

بما أنه يمكن ان يوجد انظمة قانونية تحكم اماكن التركيب المسموح بها للمراقب الملون وتختلف هذه التنظيمات من بلد الى اخر، تأكد من تركيب هذا المراقب الملون في الاماكن التي لا تتعارض مع هذه القوانين والانظمة.

Parts list for installation and connection

The following parts are provided with this unit. After checking them, please set them correctly.

安裝和連接用零件表

本機備有下列零件，在檢查這些零件之後，請正確組裝。

รายการชิ้นส่วนสำหรับการติดตั้งและการเชื่อมต่อ

ชิ้นส่วนต่อไปนี้ได้จัดเตรียมไว้ให้พร้อมกับชุดจอภาพ หลังจากตรวจสอบแล้ว โปรดติดตั้งในตำแหน่งที่ถูกต้อง

قائمة اجزاء التركيب والتوصيل

الاجزاء التالية مزودة مع الجهاز. بعد فحص هذه الاجزاء، يرجى تركيبهم بشكل صحيح.

Wide color monitor (center unit and shroud)
寬螢幕彩色監視器 (中機組和遮蓋)
จอสีขนาดกว้าง (หน่วยกลางและที่ครอบ)
المراقب الملون الواسع (الوحدة الرئيسية والغطاء)

Monitor connection unit
監視器連接機
ชุดเชื่อมต่อจอภาพ
وحدة توصيل المراقب

Extension cord (4 m)
延長用導線 (4 m)
สายต่อพวง (4 เมตร)
سلك التحويل (4 متر)

Remote controller with a battery (CR2025) installed
遙控器已置入乾電池 (CR2025)
รีโมทคอนโทรลพร้อมแบตเตอรี่ (CR2025)
وحدة التحكم عن بعد مع بطارية مركبة (CR2025)

Metal plate
金屬盤
แบตเตอรี่
صفحة معدنية

Power cord
電源線
สายไฟ
سلك الطاقة الكهربائية

Screws (M4 x 5 mm)
螺絲釘 (M4 x 5 mm)
نوت (M4 x 5 مم.)
براغي (M4 x 5 مم.)

Screws (M4 x 12 mm)
螺絲釘 (M4 x 12 mm)
نوت (M4 x 12 مم.)
براغي (M4 x 12 مم.)

Ceiling light cord
蓬頂燈導線
யகரோங்ஸெய்ரத
سلك ضوء السقف

TROUBLESHOOTING

故障排除

การแก้ไขปัญหาเบื้องต้น

البحث عن الاعطال والاصلاح

- The fuse blows.
* Are the red and black leads connected correctly?
- Power cannot be turned on.
* Is the yellow lead connected?
- Picture does not come on screen.
* Is the correct input selected?

- 保險絲燒斷。
* 紅色和黑色導線接頭是否正確連接?
- 電源不能接通。
* 黃色導線接頭是否接上?
- 螢幕不出畫面。
* 檢查是否選擇正確輸入?

- ฟิวส์ขาด
* ตรวจสอบสายไฟสีแดงและดำอย่างถูกต้องหรือไม่?
- ไม่สามารถเปิดปุ่มเปิด/ปิดได้
* ตรวจสอบสายไฟสีเหลืองแล้วหรือยัง?
- ภาพไม่ปรากฏบนจอ
* เลือกอินพุตถูกต้องหรือไม่?

- يحترق الفيوز.
* هل السلك الاحمر والاسود موصولة بشكل صحيح؟
- لا يمكن توصيل الطاقة الكهربائية.
* هل السلك الاصفر موصول؟
- لا تظهر الصورة على الشاشة.
* هل الدخل الصحيح مختارا؟

INSTALLATION

安裝

การติดตั้ง

تركيب الجهاز

The following illustration shows a typical installation. However, you should make adjustments corresponding to your specific car. If you have any questions or require information regarding installation kits, consult your JVC car audio dealer or a company supplying kits.

下面的圖解表示了典型的安裝程式。然而，您應當做些適當的調整，以便適應您自己的汽車。如果您有問題，或需要有關配套元件的資料，請向 JVC 汽車音響分銷商或配套元件供應公司詢問。

ภาพประกอบต่อไปนี้แสดงการติดตั้งตามปกติ อย่างไรก็ตาม ควรทำการปรับตำแหน่งให้เหมาะสมกับรถของท่าน หากมีคำถามหรือต้องการข้อมูลเกี่ยวกับชุดการติดตั้งโปรดปรึกษาตัวแทนจำหน่ายเครื่องเสียงรถยนต์หรือ JVC หรืออ่านจากคู่มือที่ให้มาพร้อมกัน

يبيّن الرسم التوضيحي التالي طريقة التركيب المثالية. مع ذلك، يجب عليك عمل تعديلات تطابق نوع السيارة التي تمتلكها. إذا كان هناك استفسارات أو حاجة لمعلومات بخصوص أدوات التركيب، يرجى استشارة موزع الأجهزة الصوتية للسيارات ماركة JVC أو الشركة الموزعة لهذه الأدوات.

Mounting the color monitor

Installation procedure varies among different cars. The following is an example. It is recommended to have the monitor system installed by a qualified technician.

放置彩色監視器

每種汽車的安裝程序各異。下列為其中一例子。我們建議您由合格技工安裝監視器系統。安裝監視器於車頂之前。

การติดตั้งจอสี

วิธีการติดตั้งจะแตกต่างกันไปสำหรับรถยนต์แต่ละประเภทต่อไปนี้เป็นตัวอย่างหนึ่งของรูปแบบการติดตั้ง การติดตั้งจอภาพควรกระทำโดยช่างผู้ชำนาญเท่านั้น

تركيب المراقب الملون

يختلف اجراء التركيب بين السيارات المختلفة. الاجراء التالي هو مثال. ننصح بتركيب جهاز المراقب من قبل فني مختص بهذا المجال.

Before mounting the monitor to the ceiling:

Perform the required external connections first.

首先執行必要的外部連接：

• 首先執行必要的外部連接。

ก่อนติดตั้งจอภาพเข้ากับเพดานรถ:

• ให้ทำการเชื่อมต่อภายนอกที่จำเป็นก่อน

قبل تركيب المراقب على السقف:

• اعمل اولاً التوصيل الداخلي المطلوب.

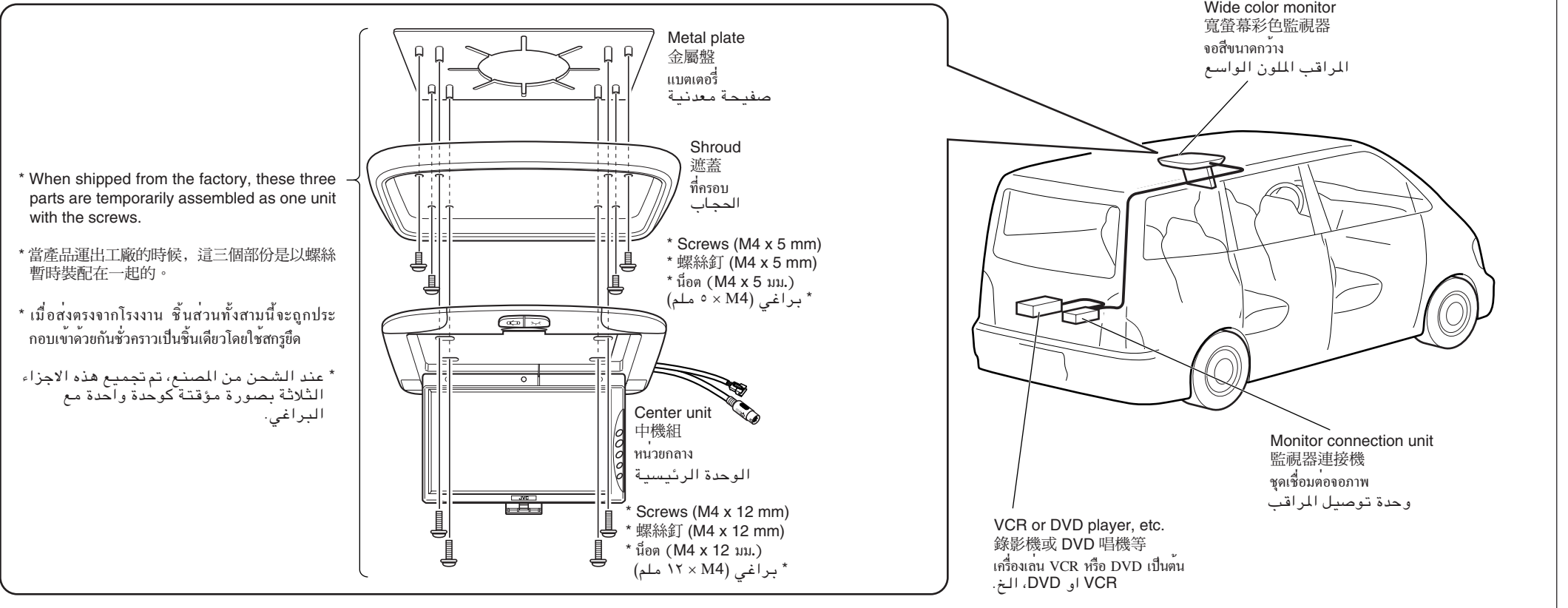

Replacing the ceiling light bulbs / 替換蓬頂燈泡 / การเปลี่ยนหลอดไฟเพดาน / إعادة تركيب لمبات ضوء السيارة

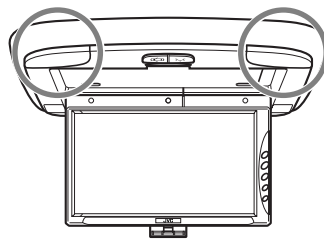

To remove the ceiling light cover, proportionally loosen the screws fixing the center unit.
要取出蓬頂燈蓋時，逐步鬆脫安裝在中機組的螺絲釘。
เพื่อถอดฝาครอบไฟเพดาน ให้ขันสกรูที่ยึดตรงส่วนกลางแผงออก
لنزع غطاء ضوء السقف، فك براغي تثبيت وحدة المركز.

1

Ceiling light cover
蓬頂燈蓋
ฝาครอบไฟเพดาน
غطاء ضوء السقف

2

Ceiling light bulb
蓬頂燈泡
หลอดไฟเพดาน
لمبة ضوء السقف



ELECTRICAL CONNECTIONS

電路連接

การเชื่อมต่อไฟฟ้า

التوصيلات الكهربائية

To prevent short circuits, we recommend that you disconnect the battery's negative terminal and make all electrical connections before installing the unit. If you are not sure how to install this unit correctly, have it installed by a qualified technician.

為防止短路，建議在安裝本機之前，斷開電池的負極，並把所有電路都連接好。如果您不能確定如何正確地安裝本機，應請合格的技術人員來安裝。

เพื่อป้องกันไฟฟ้าลัดวงจรขอแนะนำให้ท่านถอดขั้วสายไฟลบของแบตเตอรี่ออกก่อนและทำการเชื่อมต่อไฟฟ้าทั้งหมดก่อนติดตั้งชุดจอภาพหากไม่แน่ใจวิธีการติดตั้งที่ถูกต้องโปรดให้ช่างผู้ชำนาญติดตั้งให้

لمنع حدوث تقصير في الدوائر الكهربائية، نوصي بفصل طرف البطارية السالبة ثم عمل التوصيلات الكهربائية قبل تركيب الجهاز. في حالة عدم معرفتك بكيفية تركيب الجهاز بشكل صحيح، يرجى ترك عملية تركيب الجهاز لشخص مختص ومؤهل لتركيب مثل هذه الأجهزة.

Note:

This unit is designed to operate only on 12 V DC, NEGATIVE ground electrical systems. If your vehicle does not have this system, a voltage inverter is required, which can be purchased at JVC car audio dealers.

注意：

本機僅可使用直流 12V、負極接地的電源系統。如果您的車輛沒有這一電源系統，則需要一個電壓變換器，可以在 JVC 汽車音響分銷商處買到。

หมายเหตุ:

ชุดจอภาพนี้ถูกออกแบบมาให้ทำงานกับระบบไฟฟ้าขั้วลบที่ต่อสายลงดินกระแสตรงขนาด 12 V หากรถของท่านไม่ใช่ระบบนี้ จำเป็นต้องใช้อินเวอร์เตอร์ซึ่งสามารถหาซื้อได้ที่ตัวแทนจำหน่ายเครื่องเสียงรถยนต์ชื่อ JVC

ملاحظة:
لقد صمم هذا الجهاز ليعمل بواسطة تيار كهربائي مباشر DC، 12 فولت، انظمة كهربائية تأريض سالبة. في حالة عدم وجود مثل هذا النظام في سيارتك، يجب استخدام محول فولتاج، ويمكن شراء هذا المحول من وكلاء الاجهزة الصوتية للسيارات ماركة JVC.

Replace the fuse with one of the specified ratings. If the fuse blows frequently, consult your JVC car audio dealer.

把保險絲更換為額定負荷值的保險絲。如果保險絲經常燒壞，請向 JVC 汽車音響分銷商詢問。

เปลี่ยนฟิวส์โดยใช้ค่าใดค่าหนึ่งเฉพาะต่อไปนี้ หากฟิวส์ขาดบ่อยโปรดปรึกษาตัวแทนจำหน่ายเครื่องเสียงรถยนต์ชื่อ JVC

استبدل الفيوز بأخر يحمل نفس القياسات الموصوفة. إذا تكرر احتراق الفيوز، يرجى استشارة وكلاء الاجهزة الصوتية للسيارات ماركة JVC.

Monitor connection unit / 監視器連接機 / ชุดเชื่อมต่อจอภาพ / وحدة توصيل المراقب

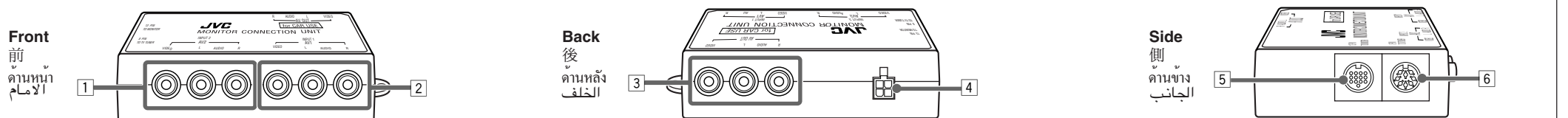

- 1 AV 2 (INPUT 2) jacks
• VIDEO/AUDIO L(left)/AUDIO R (right)
- 2 AV 1 (INPUT 1) jacks
• VIDEO/AUDIO L(left)/AUDIO R (right)
- 3 AV OUT jacks
• VIDEO/AUDIO L(left)/AUDIO R (right)
- 4 Power Supply connector
- 5 TO MONITOR (13 PIN) connector
- 6 TO TV TUNER (8 PIN) connector

- 1 AV 2 (INPUT 2) 插孔
• VIDEO/AUDIO L (左) /AUDIO R (右)
- 2 AV 1 (INPUT 1) 插孔
• VIDEO/AUDIO L (左) /AUDIO R (右)
- 3 AV OUT 插孔
• VIDEO/AUDIO L (左) /AUDIO R (右)
- 4 電源連接器
- 5 TO MONITOR (13 管腳) 連接器
- 6 TO TV TUNER (8 管腳) 連接器

- 1 แจ็ค AV 2 (INPUT 2)
• VIDEO/AUDIO L (ซ้าย)/AUDIO R (ขวา)
- 2 แจ็ค AV 1 (INPUT 1)
• VIDEO/AUDIO L (ซ้าย)/AUDIO R (ขวา)
- 3 แจ็ค AV OUT
• VIDEO/AUDIO L (ซ้าย)/AUDIO R (ขวา)
- 4 ขั้วต่อพาวเวอร์ซัพพลาย
- 5 ขั้วต่อ TO MONITOR (13 PIN)
- 6 ขั้วต่อ TO TV TUNER (8 PIN)

- 1 مقابس الدخل AV 2 (INPUT 2)
• الفيديو VIDEO/الصوت (الايسر) /AUDIO L
الصوت (اليمين) /AUDIO R
- 2 مقابس الدخل AV 1 (INPUT 1)
• الفيديو VIDEO/الصوت (الايسر) /AUDIO L
الصوت (اليمين) /AUDIO R
- 3 مقابس الخرج AV OUT
• الفيديو VIDEO/الصوت (الايسر) /AUDIO L
الصوت (اليمين) /AUDIO R
- 4 موصل مصدر الطاقة الكهربائية
- 5 الى موصل المراقب (TO MONITOR) (13 دبوس)
- 6 الى موصل موالف التلفزيون (TO TV TUNER) (8 دبوس)

Typical Connections / 典型連接 / การเชื่อมต่อแบบทั่วไป / التوصيلات النموذجية

Before connecting: Check the wiring in the vehicle carefully. Incorrect connection may cause serious damage to this unit. The leads of the power cord and the ceiling light cord and those of the connector from the car body may be different in color.

連接之前：請仔細檢查汽車內的接線。錯誤的接線可能導致本機嚴重損傷。電纜的軟線和頂燈電線和汽車車身的連接器可能不同顏色。

ก่อนการเชื่อมต่อ: โปรดตรวจสอบการเดินสายไฟในรถอย่างรอบคอบ การต่อสายไฟที่ไม่ถูกต้องอาจสร้างความเสียหายขั้นรุนแรงให้กับชุดจอภาพนี้ได้

قبل البدء بالتوصيل: تأكد من شبكة الاسلاك في السيارة بدقة. يمكن ان يسبب التوصيل الخاطيء الي حصول عطل حقيقي للجهاز. سلك الطاقة الكهربائية وسلك ضوء السقف واسلاك الموصل من هيكل السيارة يمكن ان تختلف باللون.

Power supply connection

- 1 Connect the colored leads of the power cord in the following sequence.
1 Black: ground
2 Yellow: to car battery (constant 12 V)
3 Red: to an accessory terminal
4 Blue: to remote control lead of the external component (such as KS-IF200).
2 Finally connect the wiring harness to the unit.

- 1 按照下列程序連接標有顏色的電源線。
1 黑色：接地
2 黃色：接至汽車電池（恆定 12 V）
3 紅色：接至附屬的端子
4 藍色：至外部組件的遙控器電線（如 KS-IF200）。
2 最後將導線連接到本機。

- การเชื่อมต่อสายไฟ
1 ต่อสายไฟที่เป็นสีตามลำดับดังต่อไปนี้
1 สีดำ: ต่อกับสายดิน
2 สีเหลือง: ต่อกับแบตเตอรี่ (แบบคงที่ ขนาด 12 V)
3 สีแดง: ต่อกับอุปกรณ์
4 สายสีน้ำเงิน: ต่อกับสายรีโมตคอนโทรลของอุปกรณ์ภายนอก (ได้แก่ KS-IF200)
2 ชั้นสุดท้ายให้ต่อสายไฟเข้ากับชุดจอภาพ

- توصيل مصدر الطاقة الكهربائية
1 اوصل الاسلاك الملونة لسلك الطاقة الكهربائية بالتسلسل التالي.
1 السلك الاسود: مع الارض
2 السلك الاصفر: مع بطارية السيارة (ثابت ١٢ فولت)
3 السلك الاحمر: مع الطرف الاضافي
4 الازرق: مع سلك وحدة التحكم عن بعد للكيبونات الخارجية (مثل KS-IF200).
2 اخيرا، اوصل حامل الاسلاك مع الجهاز.

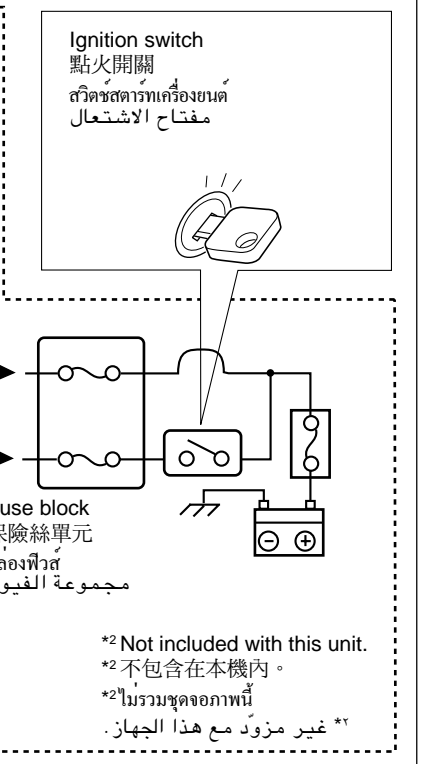
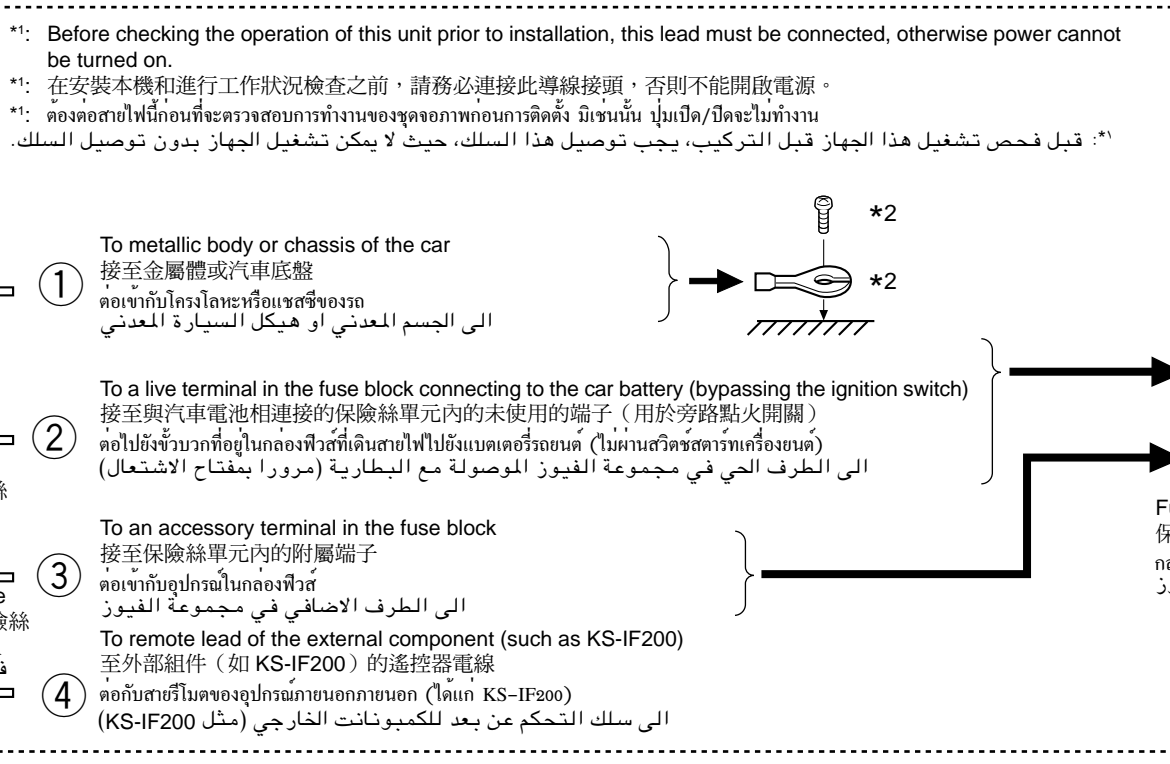
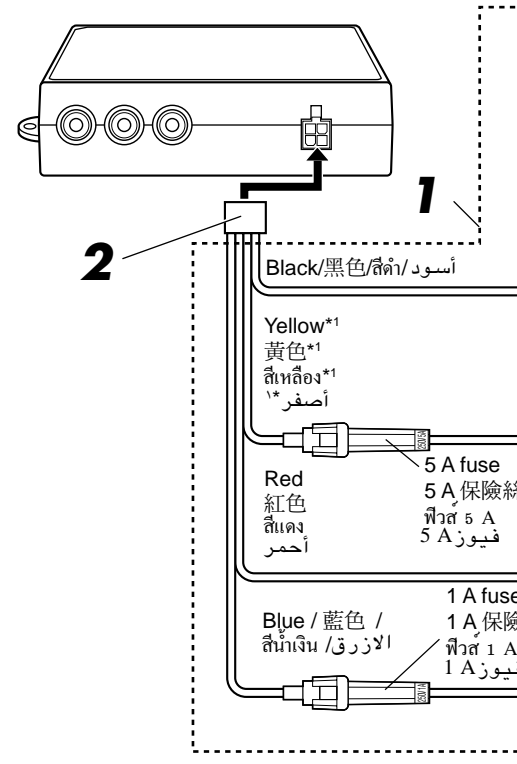

Ceiling light wire connection

- 1 Connect the colored leads of the ceiling light cord in the following sequence.
1 Black: ground (GND)
2 Yellow: to car battery (constant 12 V) (BATTERY B+)
3 Red: to an accessory terminal (ACC)
4 Grey: to the door sensor (DOOR SW)

- 1 按照下列程序連接頂燈的顏色電線。
1 黑色：接地（GND）
2 黃色：接至汽車電池（恆定 12 V）（BATTERY B+）
3 紅色：接至附屬的端子（ACC）
4 灰色：至車門感應器（DOOR SW）

- การเชื่อมต่อสายไฟเพดาน
1 ต่อสายไฟสีต่างๆ ของไฟเพดานตามลำดับดังต่อไปนี้
1 สีดำ: ต่อกับสายดิน (GND)
2 สีเหลือง: ต่อกับแบตเตอรี่ (แบบคงที่ ขนาด 12 V) (BATTERY B+)
3 สีแดง: ต่อกับอุปกรณ์ (ACC)
4 สีเทา: ต่อกับสวิทช์เซ็นเซอร์ประตู (DOOR SW)

- توصيل سلك ضوء السقف
1 اوصل الاسلاك الملونة لسلك ضوء السقف في الترتيب التالي.
1 السلك الاسود: مع الارض (GND)
2 السلك الاصفر: مع بطارية السيارة (ثابت ١٢ فولت) (BATTERY B+)
3 السلك الاحمر: مع الطرف الاضافي (ACC)
4 الرمادي: مع مفتاح حساس الباب (DOOR SW)

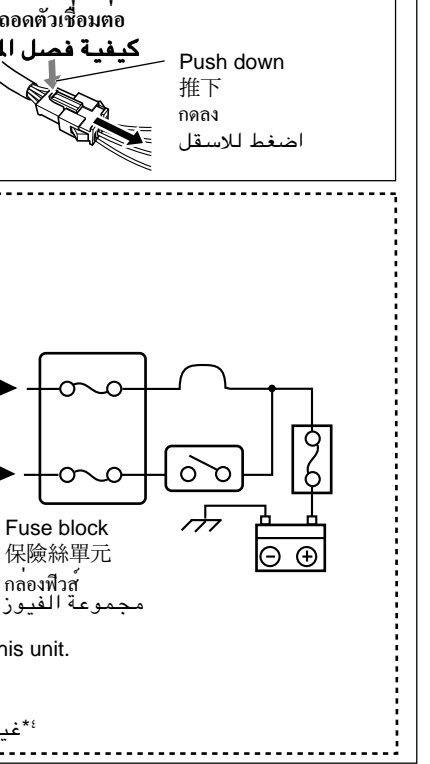
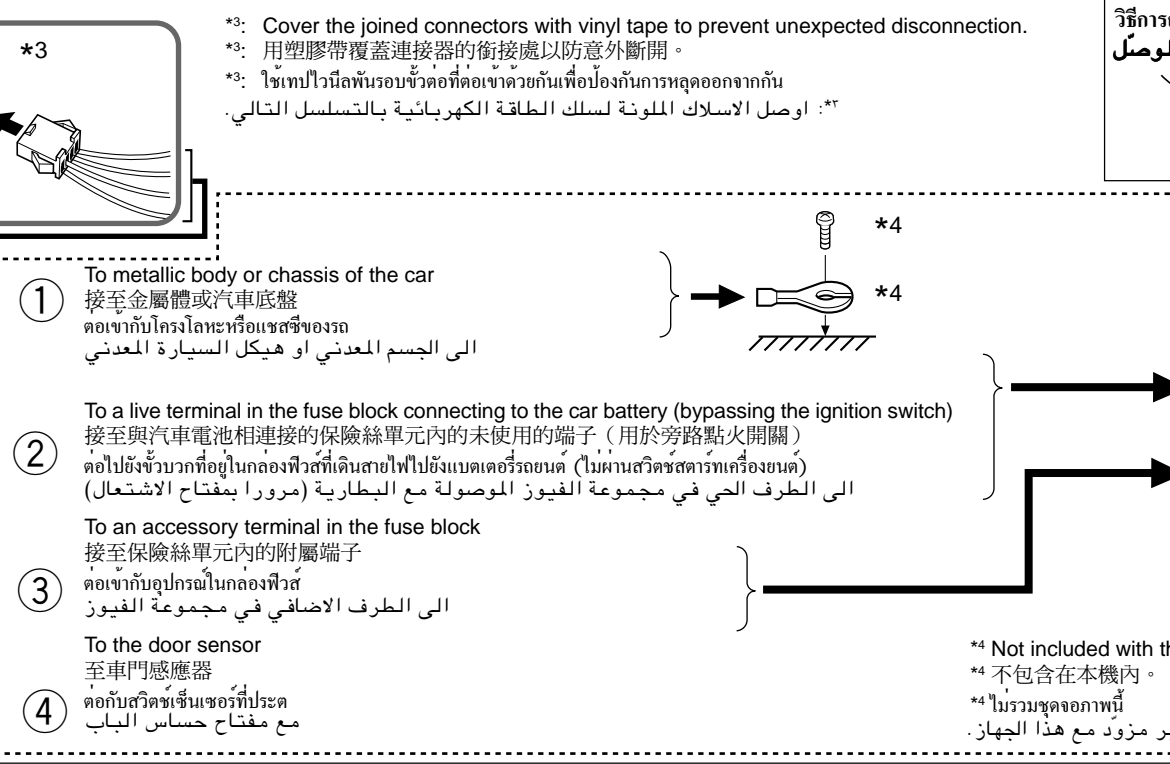
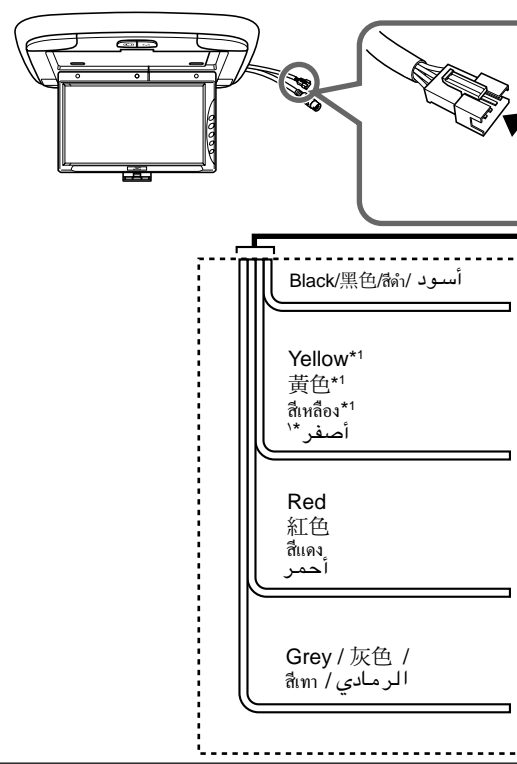

Connecting the leads / 連接電線 / การเชื่อมต่อสายไฟ / توصيل الاسلاك

Twist the core wires when connecting. 連接時彎曲電線芯心。 มวนสายไฟหลักขณะเชื่อมต่อ. انزع المادة العازلة قبل التوصيل.

Solder the core wires to connect them securely. 銲接電線芯心以將它們穩固連接。 บัดกรีสายไฟหลักจากควยกันอยางแนนหนา. اللحم الاسلاك للتوصيلهم بصورة آمنة.

CAUTION / 注意 / ข้อควรระวัง / تنبيه
• To prevent short-circuit, cover the terminals of the UNUSED leads with insulating tape.
• 為免電源短路，用絕緣膠帶包裹 UNUSED（不使用）電線的終端。
• ควรใช้เทปพันรอบปลายสายไฟที่ไม่ได้ใช้ เพื่อป้องกันไฟฟัดวงจร
• لمنع تقصير - الدائرة، ضع شريط عازل على اطراف الاسلاك غير المستعملة.

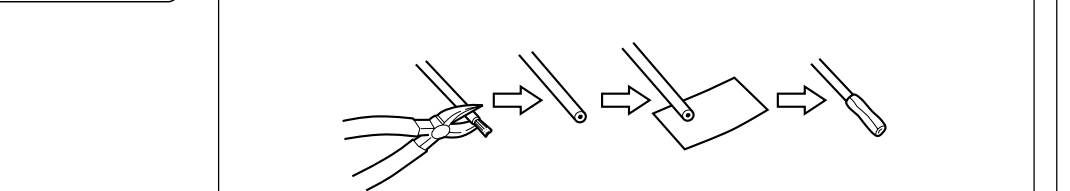
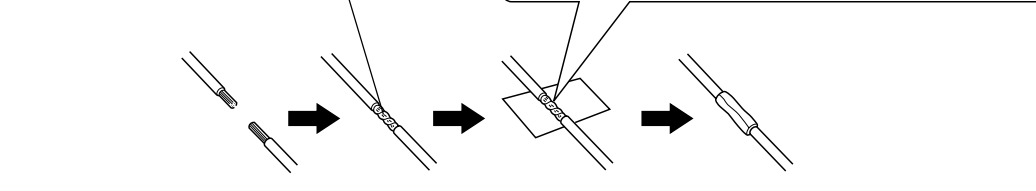

CONNECTING THE EXTERNAL COMPONENTS

連接外部組件

Connect the monitor to TO MONITOR jack. If the monitor cord is not long enough for connection, use the extension cord supplied with the unit. The monitor connection unit provides 2 input circuits and 1 output circuit. Connect one or two playback sources to AV 1 (INPUT 1) and/or AV 2 (INPUT 2) and connect reproducing components, such as a car receiver, to AV OUT.

將監視器連接至 TO MONITOR (至監視器) 插孔。若監視器導線不夠長以進行連接，用隨機附帶的延長電線。監視器連接機提供 2 個輸入電路和 1 個輸出電路。將一個或兩個播放源連接至 AV 1 (INPUT 1) 及 / 或 AV 2 (INPUT 2) 並連接再現組件，如汽車接收器至 AV OUT。

การเชื่อมต่ออุปกรณ์ภายนอก

ต่อจอภาพเข้ากับแจ็ก TO MONITOR หากสายไฟจอกาพยาวไม่พอสำหรับเชื่อมต่อ ให้ใช้สายต่อพ่วงที่นำมาพร้อมกับชุดจอกาพ แผงต่อจอกาพมีวงจรอินพุต 2 ชุด และวงจรเอาต์พุต 1 ชุด เชื่อมต่อเครื่องเล่นหนึ่งหรือสองตัวเข้ากับ AV 1 (INPUT 1) และ/หรือ AV 2 (INPUT 2) และเชื่อมต่อส่วนประกอบอื่น ๆ เช่น เครื่องรับวิทยุภายในรถ เข้าที่ AV OUT

توصيل اجهزة الكمبيوتر الخارجية

اوصل المراقب مع مقبس TO MONITOR. اذا كان سلك المراقب غير طويل بصفة كافية للتوصيل، استعمل سلك التطويل المرفق مع الجهاز. تزود وحدة توصيل المراقب 2 دائرة دخل و 1 دائرة خرج. اوصل مصدر او مصدري تشغيل مع طرف الدخل AV 1 (INPUT 1) و/او طرف الدخل AV 2 (INPUT 2) واصل كمبيوترات التشغيل مثل مستقبل السيارة مع طرف الخرج AV OUT.

• When not using the mobile TV tuner system KV-C10 / 當不使用流動電視調諧器系統 KV-C10 時 / เมื่อไม่ได้ใช้ระบบจูนทีวีเคลื่อนที่ KV-C10 / مثل عند عدم استعمال جهاز موالف التلفزيون المتحرك، KV-C10

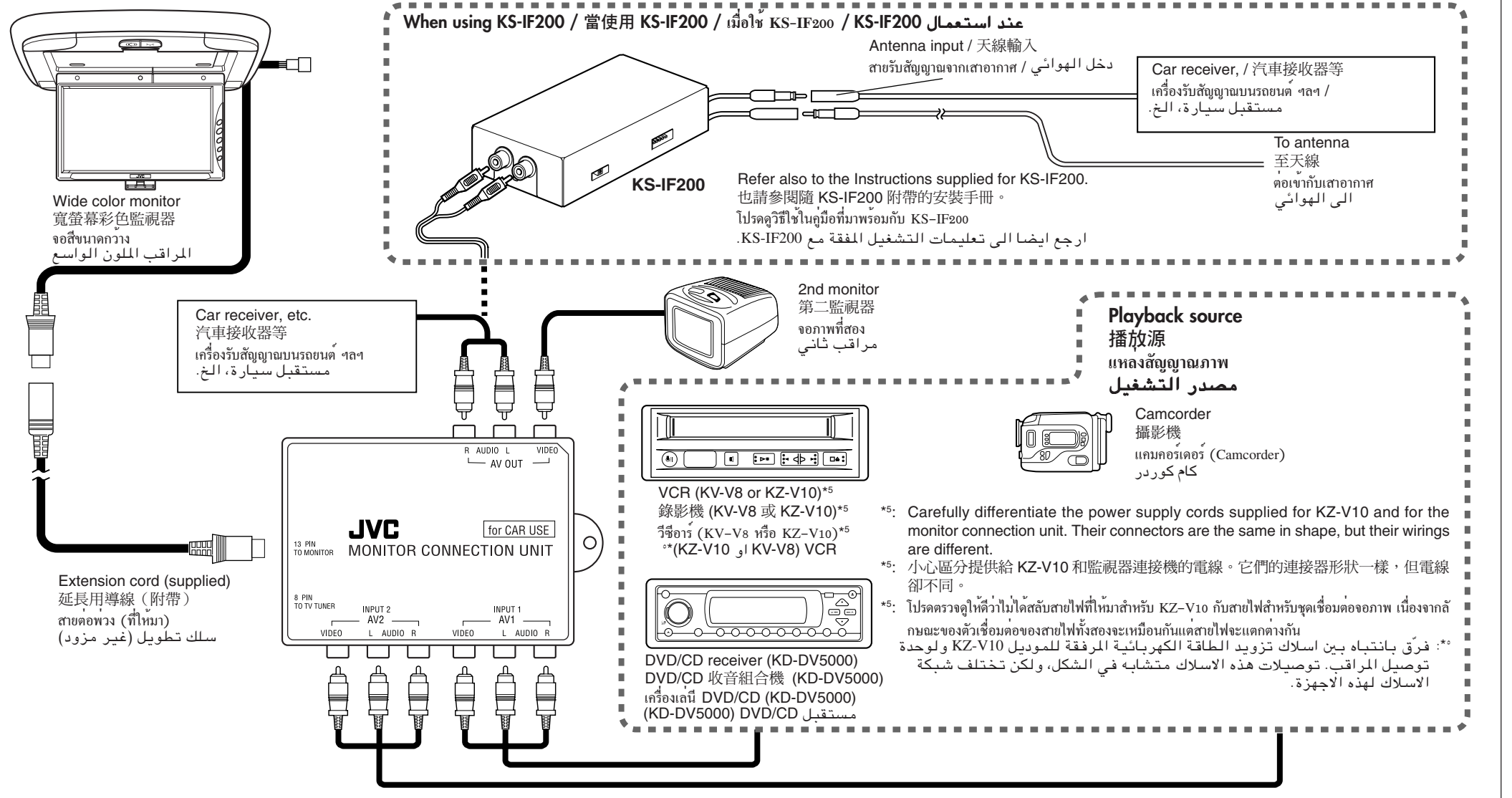

• When using the mobile TV tuner system KV-C10 / 當使用流動電視調諧器系統 KV-C10 時 / เมื่อใช้ระบบจูนทีวีเคลื่อนที่ KV-C10 / KV-C10 مثل عند استعمال جهاز موالف التلفزيون المتحرك، KV-C10

